

CCD-TR311/TR311E/TR411E/TR412E/TR511E/ TR512E/TR640E/TR730E/TR840E/TR845E RMT-708/717

SERVICE MANUAL

Self Diagnostics
Supported model



Photo : CCD-TR840E
: RMT-708

Handycam
Video 8 XR
video Hi8 XR

B MECHANISM

AEP Model
CCD-TR411E/TR412E/TR511E/TR640E/TR840E/
TR845E

UK Model
CCD-TR411E/TR511E/TR640E/TR840E

East European Model
North European Model

Russian Model
CCD-TR411E/TR412E/TR511E/TR640E/TR840E

E Model
CCD-TR311/TR311E/TR511E/TR512E/TR730E

Hong Kong Model
CCD-TR311E/TR511E

Australian Model
CCD-TR311E/TR511E/TR512E/TR840E

Tourist Model
CCD-TR311/TR311E

Chinese Model
CCD-TR311E/TR511E/TR512E

SPECIFICATIONS

For MECHANISM ADJUSTMENTS, refer to the "8mm Video MECHANICAL ADJUSTMENT MANUAL VII" (9-973-801-11).

Video camera recorder System

Video recording system
2 Rotary heads
Helical scanning FM system
Audio recording system
Rotary heads, FM system
Video signal
CCD-TR311 : NTSC color, EIA standards
CCD-TR311E/TR411E/TR511E/
TR512E/TR640E/TR730E/TR840E/
TR845E : PAL color, EIA standards
Usable cassette
8mm video format cassette
CCD-TR311/TR311E/TR411E/TR412E/
TR511E/TR512E/TR640E/TR730E :
standard 8
CCD-TR840E/TR845E :
Hi8 or standard 8
Recording / Playback time
(using 90 min. cassette)
SP mode: 1 hour and 30 minutes
LP mode: 3 hours
Fastforward/rewind time
(using 90 min. cassette)
Approx. 5 min.
Image device
CCD (Charge Coupled Device)
Viewfinder
Electronic viewfinder
CCD-TR311/TR311E/TR411E/TR412E/
TR511E/TR640E/TR840E/TR845E :
Monochrome
CCD-TR512E/TR730E :
Color 113,578 (521 x 218)

Lens
Combined power zoom lens
Filter diameter 1 7/16 in. (37 mm)
CCD-TR411E (AEP, UK) :
16 x (Optical), 32 x (Digital)
CCD-TR412E (AEP) :
16 x (Optical), 64 x (Digital)
CCD-TR311/TR311E :
16 x (Optical), 100 x (Digital)
CCD-TR411E (EE, NE, RU) :
16 x (Optical), 160 x (Digital)
CCD-TR412E (EE, NE, RU) :
16 x (Optical), 200 x (Digital)
CCD-TR511E (AEP, UK)/TR640E
(AEP, UK)/TR840E (AEP, UK)/
TR845E : 18 x (Optical), 72 x (Digital)
CCD-TR511E (EE, NE, RU, E, HK,
AUS, CN)/TR512E/TR640E (EE, NE, RU,
AUS) : 18 x (Optical), 220 x (Digital)
Focal distance
CCD-TR311/TR311E/TR411E/
TR412E :
3/16 - 2 5/8 in. (4.1 - 65.6 mm)
CCD-TR511E/TR512E/TR640E/
TR730E/TR840E/TR845E :
3/16 - 8 in. (4.1 - 73.8 mm)
When converted to a 35 mm still
camera
CCD-TR311/TR311E/TR411E/
TR412E :
1 9/16 - 24 7/8 in. (39.4 - 630 mm)
CCD-TR511E/TR512E :
1 9/16 - 28 in. (39.4 - 709 mm)
CCD-TR640E/TR730E/TR840E/
TR845E :
1 7/8 - 33 1/2 in. (47.2 - 850 mm)

Color temperature
Auto
Minimum illumination*
CCD-TR311/TR311E/TR411E/TR412E :
0.4 lux at F1.4 (Visible minimum low
light 0.2 lux)
CCD-TR511E/TR512E :
0.4 lux at F 1.4
CCD-TR640E/TR730E/TR840E/
TR845E : 0.7 lux at F 1.4
CCD-TR511E/TR512E/TR640E/
TR730E/TR840E/TR845E :
0 lux (in NightShot mode)**
* Minimum illumination
expresses the light level a camcorder
requires to produce a picture. Visible
minimum low light expresses the light
level to produce a visible signal.
**Object invisible for the dark can be
shot with infrared lighting.
Illumination range
CCD-TR311/TR311E/TR411E/
TR412E/TR511E/TR512E :
0.4 lux to 100,000 lux
CCD-TR640E/TR730E/TR840E/
TR845E : 0.7 lux to 100,000 lux
Recommended illumination
More than 100 lux

Input and output connectors
S video input/output
(CCD-TR840E/TR845E only)
4-pin mini DIN
Luminance signal :
1 Vp-p, 75 ohms, unbalanced
CCD-TR311 :
Chrominance signal :
0.286 Vp-p, 75 ohms, unbalanced
CCD-TR311E/TR411E/TR412E/
TR511E/TR512E/TR640E/TR730E/
TR840E/TR845E :
Chrominance signal :
0.3 Vp-p, 75 ohms, unbalanced
Video input
(CCD-TR840E : AUS only)/output
Phono jack :
1 Vp-p, 75 ohms, unbalanced

— Continued on next page —

8 VIDEO CAMERA RECORDER
CCD-TR311/TR311E/TR411E/TR412E/TR511E/TR512E/TR640E/TR730E
Hi8 VIDEO CAMERA RECORDER
CCD-TR840E/TR845E



SONY[®]

Table for difference of function

Model	CCD-TR311	CCD-TR311E	CCD-TR411E	CCD-TR412E	CCD-TR511E	CCD-TR511E	CCD-TR511E	Remark
Destination	E, JE	E, AUS, HK, CN, JE	AEP, UK, EE, NE, RU	AEP, EE, NE, RU	AEP, UK, EE, NE, RU	E, HK, AUS, CN		
Color System	NTSC	PAL	PAL	PAL	PAL	PAL		
Classification	TYPE E	TYPE D	TYPE D	TYPE D	TYPE D	TYPE D		
Remote Commander	X	X	X	RMT-708	RMT-708	RMT-708		
Hi8	X	X	X	X	X	X		
Standard 8	O	O	O	O	O	O		
Lens	16X	16X	16X	16X	18X	18X		16X : LSV601A, 18X : LSV600A
	100X	100X	32X(Note1)	64X(Note2)	72X(Note3)	220X		
CCD	510H	510H	510H	510H	510H	510H		O : LSV600A
Night shot	X	X	X	X	O	O		
Steady shot	X	X	X	X	X	X		
Photo mode	X	X	X	X	X	X		
Digital effect	X	X	X	X	X	X		
Audio system	Mono	Mono	Mono	Mono	Mono	Mono		
TBC&DNR	X	X	X	X	X	X		
Time code	X	X	X	X	X	X		
VTR REC	X	X	X	X	X	X		
Color EVF	X	X	X	X	X	X		
B/W EVF	O	O	O	O	O	O		O : with VF-99 board
Intelligent accessory shoe	X	X	X	X	X	X		
Normal accessory shoe	X	X	X	X	O	O		
LCD indicator backlight	X	X	X	X	X	X		
Manual focus	X	X	X	X	O	O		O : with MF-8500 block

Model	CCD-TR512E	CCD-TR640E	CCD-TR730E	CCD-TR840E	CCD-TR840E	CCD-TR845E	Remark
Destination	E, AUS, CN	AEP, UK, EE, NE, RU	E	AEP, UK, EE, NE, RU	AUS	AEP	
Color System	PAL	PAL	PAL	PAL	PAL	PAL	
Classification	TYPE A	TYPE C	TYPE G	TYPE B	TYPE F	TYPE H	
Remote Commander	RMT-708	RMT-708	RMT-708	RMT-708	RMT-708	RMT-717	
Hi8	X	X	X	X	X	X	
Standard 8	O	O	O	O	O	O	
Lens	18X	18X	18X	18X	18X	18X	
	220X	72X(Note3)	220X	72X(Note3)	220X	72X	
CCD	510H	760H	760H	760H	760H	760H	
Night shot	O	O	O	O	O	O	
Steady shot	X	O	O	O	O	O	
Photo mode	X	X	O	X	X	X	
Digital effect	X	X	O	X	X	X	
Audio system	Mono	Mono	Stereo	Stereo	Stereo	Stereo	
TBC&DNR	X	X	O	O	O	O	
Time code	X	X	X	X	X	X	
VTR REC	X	X	X	X	X	X	
Color EVF	O	O	O	O	O	O	
B/W EVF	X	X	X	X	X	X	
Intelligent accessory shoe	X	X	O	O	O	O	
Normal accessory shoe	O	O	X	X	X	X	
LCD indicator backlight	X	X	X	X	O	O	
Manual focus	O	O	O	O	O	O	

Note1 : EE,NE,RU model is 160X
Note2 : EE,NE,RU model is 200X
Note3 : EE,NE,RU model is 220X

• Abbreviation

EE : East European Model
 NE : North European Model
 RU : Russian Model
 HK : Hong Kong Model
 AUS : Australian Model
 JE : Tourist Model
 CN : Chinese Model

SELF-DIAGNOSIS FUNCTION

1. Self-diagnosis Function

When problems occur while the unit is operating, the self-diagnosis function starts working, and displays on the viewfinder what to do. This function consists of two display; self-diagnosis display and service mode display.

Details of the self-diagnosis functions are provided in the Instruction manual.

2. Self-diagnosis display

When problems occur while the unit is operating, the counter of the viewfinder shows a 4-digit display consisting of an alphabet and numbers, which blinks at 3.2 Hz. This 5-character display indicates the “repaired by:”, “block” in which the problem occurred, and “detailed code” of the problem.

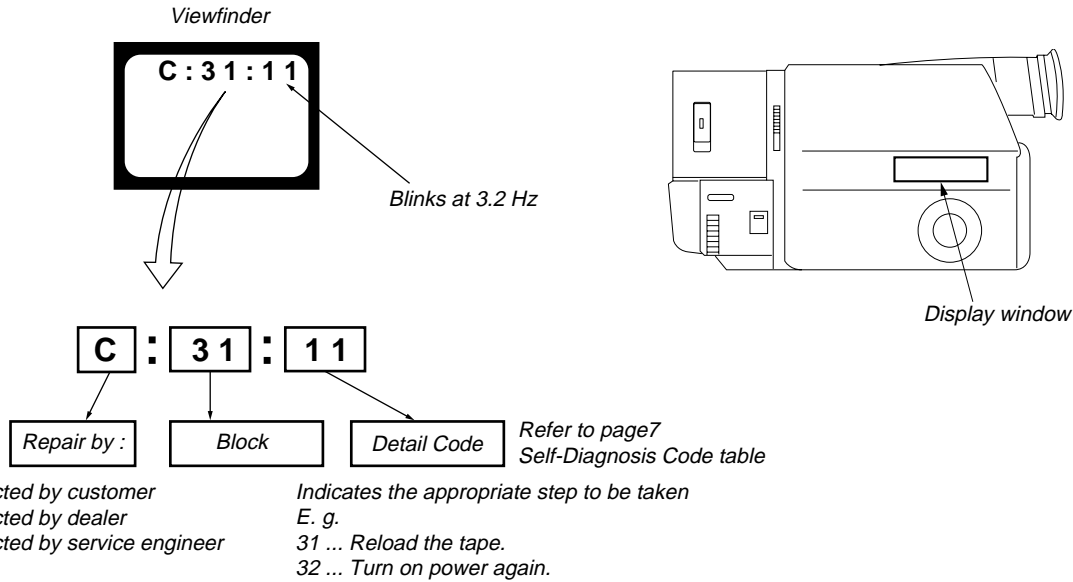

3. Service Mode Display

The service mode display shows up to six self-diagnosis codes shown in the past.

3-1. Display Method

While pressing the “STOP” key, set the switch from OFF to “VTR or PLAYER”, and continue pressing the “STOP” key for 5 seconds continuously. The service mode will be displayed, and the counter will show the backup No. and the 5-character self-diagnosis codes.

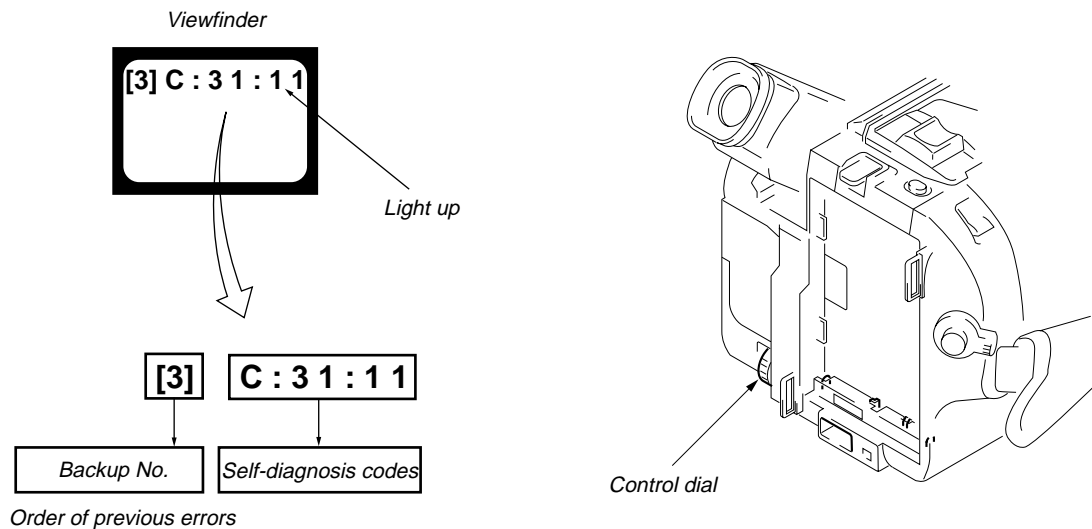

3-2. Switching of Backup No.

By rotating the control dial, past self-diagnosis codes will be shown in order. The backup No. in the [] indicates the order in which the problem occurred. (If the number of problems which occurred is less than 6, only the number of problems which occurred will be shown.)

- | | |
|----------------------------|------------------------------|
| [1] : Occurred first time | [4] : Occurred fourth time |
| [2] : Occurred second time | [5] : Occurred fifth time |
| [3] : Occurred third time | [6] : Occurred the last time |

3-3. End of Display

Turning OFF the power supply will end the service mode display.

Note: The self-diagnosis display data will be backed up by the coin-type lithium battery. When this coin-type lithium battery is disconnected, the self-diagnosis data will be lost by initialization.

4. Self-diagnosis Code Table

Self-diagnosis Code					Symptom/State	Correction
	Repaired by:	Block Function	Detailed Code			
C	2	1	0	0	Condensation.	Remove the cassette, and insert it again after one hour.
C	2	2	0	0	Video head is dirty.	Clean with the optional cleaning cassette.
C	2	3	0	0	Non-standard battery is used.	Use the InfoLITHIUM battery.
C	3	1	1	0	LOAD direction. Loading does not complete within specified time	Load the tape again, and perform operations from the beginning.
C	3	1	1	1	UNLOAD direction. Loading does not complete within specified time	Load the tape again, and perform operations from the beginning.
C	3	1	2	0	T reel side tape slacking when unloading.	Load the tape again, and perform operations from the beginning.
C	3	1	2	1	S reel side tape slacking when unloading.	Load the tape again, and perform operations from the beginning.
C	3	1	2	2	T reel fault	Load the tape again, and perform operations from the beginning.
C	3	1	2	3	S reel fault	Load the tape again, and perform operations from the beginning.
C	3	1	3	0	FG fault when starting capstan	Load the tape again, and perform operations from the beginning.
C	3	1	3	1	FG fault during normal capstan operations	Load the tape again, and perform operations from the beginning.
C	3	1	4	0	FG fault when starting drum	Load the tape again, and perform operations from the beginning.
C	3	1	4	1	PG fault when starting drum	Load the tape again, and perform operations from the beginning.
C	3	1	4	2	FG fault during normal drum operations	Load the tape again, and perform operations from the beginning.
C	3	1	4	3	PG fault during normal drum operations	Load the tape again, and perform operations from the beginning.
C	3	1	4	4	Phase fault during normal drum operations	Load the tape again, and perform operations from the beginning.
C	3	2	1	0	LOAD direction loading motor time-out	Remove the battery or power cable, connect, and perform operations from the beginning.
C	3	2	1	1	UNLOAD direction loading motor time-out	Remove the battery or power cable, connect, and perform operations from the beginning.
C	3	2	2	0	T reel side tape slacking when unloading.	Remove the battery or power cable, connect, and perform operations from the beginning.
C	3	2	2	1	S reel side tape slacking when unloading.	Remove the battery or power cable, connect, and perform operations from the beginning.
C	3	2	2	2	T reel fault	Remove the battery or power cable, connect, and perform operations from the beginning.
C	3	2	2	3	S reel fault	Remove the battery or power cable, connect, and perform operations from the beginning.
C	3	2	3	0	FG fault when starting capstan	Remove the battery or power cable, connect, and perform operations from the beginning.
C	3	2	3	1	FG fault during normal capstan operations	Remove the battery or power cable, connect, and perform operations from the beginning.
C	3	2	4	0	FG fault when starting drum	Remove the battery or power cable, connect, and perform operations from the beginning.
C	3	2	4	1	PG fault when starting drum	Remove the battery or power cable, connect, and perform operations from the beginning.
C	3	2	4	2	FG fault during normal drum operations	Remove the battery or power cable, connect, and perform operations from the beginning.
C	3	2	4	3	PG fault during normal drum operations	Remove the battery or power cable, connect, and perform operations from the beginning.
C	3	2	4	4	Phase fault during normal drum operations	Remove the battery or power cable, connect, and perform operations from the beginning.
E	6	1	0	0	Difficult to adjust focus (Cannot initialize focus.)	Inspect the lens block focus reset sensor (Pin ⑲ of CN551 of VC-195 board) when focusing is performed when the focus dial is rotated in the focus manual mode and the focus motor drive circuit (IC552 of VC-195 board) when the focusing is not performed. Note : Use the remote commander RM-95 only for the model without the focus dial.
E	6	1	1	0	Zoom operations fault (Cannot initialize zoom lens.)	Inspect the lens block zoom reset sensor (Pin ⑳ of CN551 of VC-195 board) when zooming is performed when the zoom lens is operated and the zoom motor drive circuit (IC552 of VC195 board) when zooming is not performed.
E	6	2	0	0	Handshake correction function does not work well.(With pitch angular velocity sensor output stopped)	Inspect pitch angular velocity sensor (SE451 of SE-65 board) peripheral circuits.
E	6	2	0	1	Handshake correction function does not work well.(With yaw angular velocity sensor output stopped)	Inspect yaw angular velocity sensor (SE452 of SE-65 board) peripheral circuits.

2-15. CIRCUIT BOARDS LOCATION

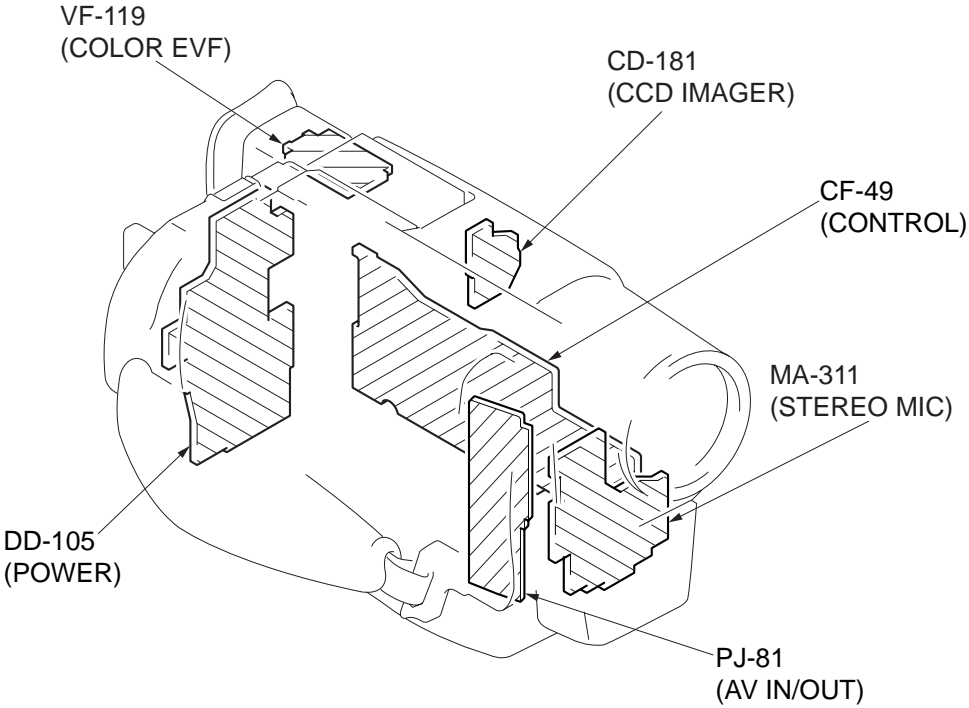
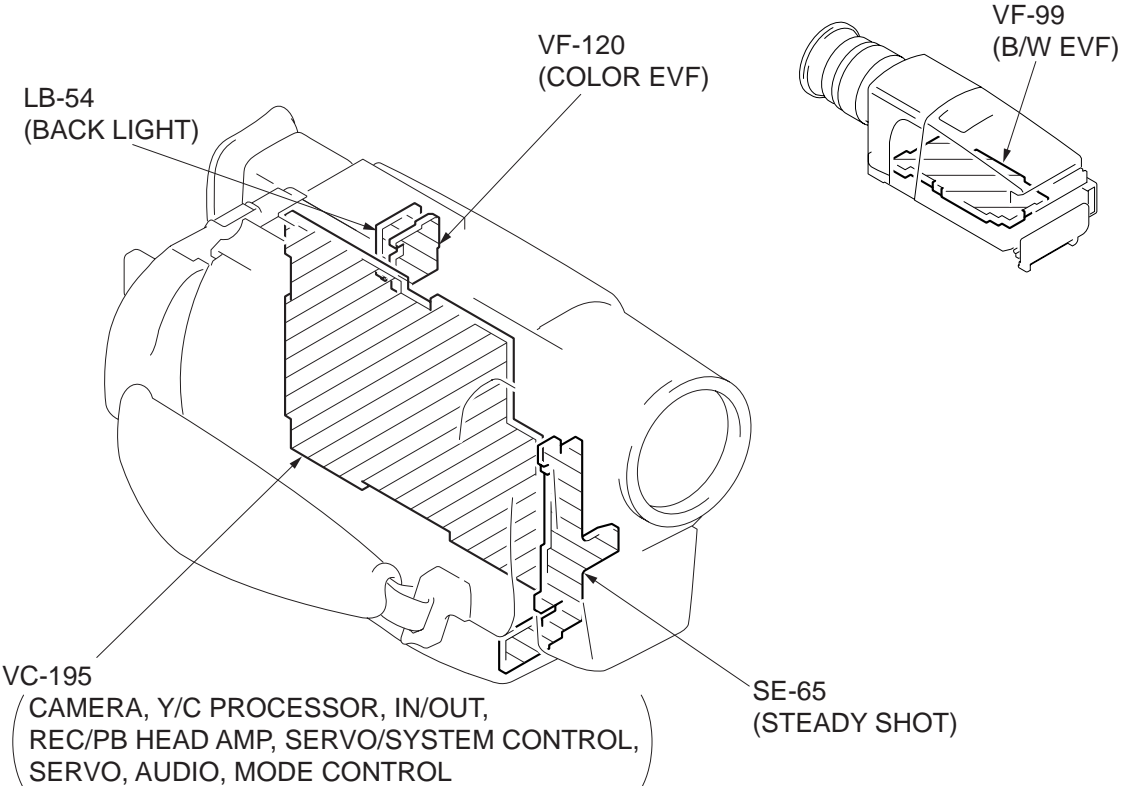

SECTION 3
BLOCK DIAGRAMS

3-1. OVERALL BLOCK DIAGRAM

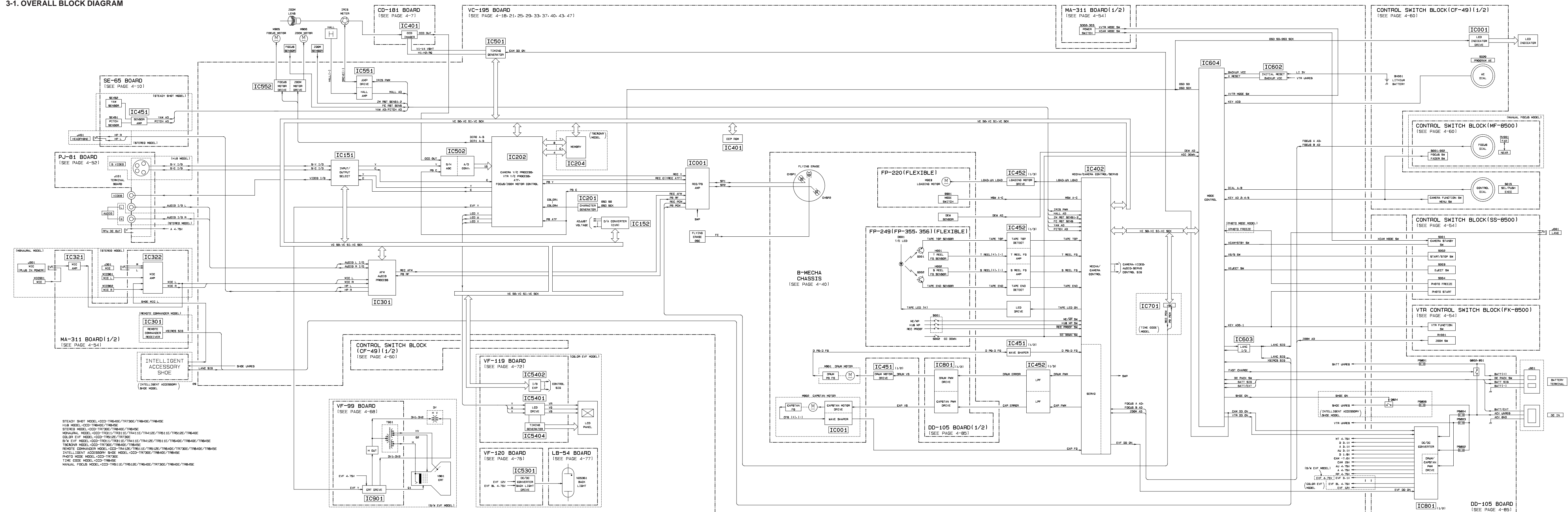

STEADY SHOT MODEL: CCD-TR840E/TR730E/TR840E/TR845E
 HI8 MODEL: CCD-TR840E/TR845E
 STEREO MODEL: CCD-TR730E/TR840E/TR845E
 MONAURAL MODEL: CCD-TR311/TR311E/TR411E/TR412E/TR511E/TR512E/TR640E
 COLOR EVF MODEL: CCD-TR512E/TR730E
 B/W EVF MODEL: CCD-TR311/TR311E/TR411E/TR412E/TR511E/TR640E/TR840E/TR845E
 TRACKING MODEL: CCD-TR730E/TR840E/TR845E
 REMOTE COMMANDER MODEL: CCD-TR412E/TR511E/TR512E/TR640E/TR730E/TR840E/TR845E
 INTELLIGENT ACCESSORY SHOE MODEL: CCD-TR730E/TR840E/TR845E
 PHOTO MODE MODEL: CCD-TR730E
 TIME CODE MODEL: CCD-TR840E
 MANUAL FOCUS MODEL: CCD-TR511E/TR512E/TR640E/TR730E/TR840E/TR845E

3-2. CAMERA/VIDEO BLOCK DIAGRAM

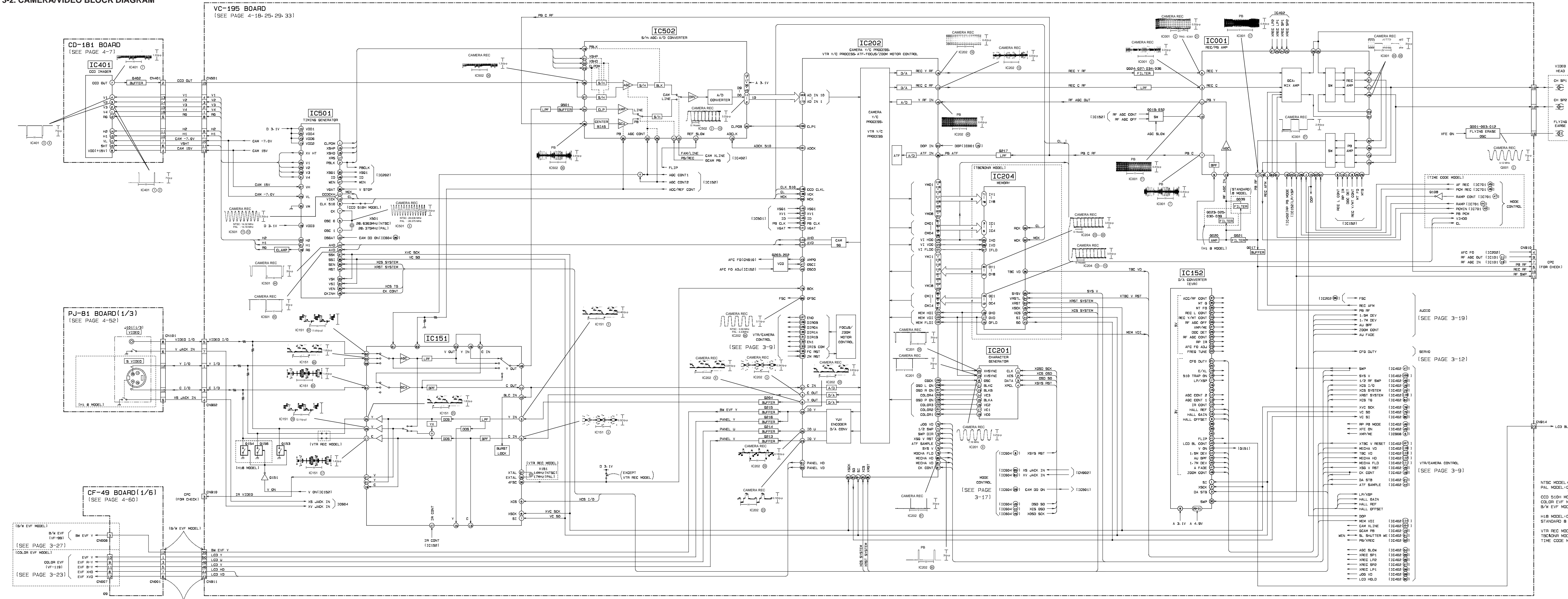

NTSC MODEL: CCD-TR311
PAL MODEL: CCD-TR311E/TR411E/TR412E/TR511E/TR512E/TR640E/TR730E/TR840E/TR845E
CCD S10H MODEL: CCD-TR311/TR311E/TR411E/TR412E/TR511E/TR512E/TR640E/TR730E/TR840E/TR845E
B/W EVF MODEL: CCD-TR311/TR311E/TR411E/TR412E/TR511E/TR512E/TR640E/TR730E/TR840E/TR845E
H18 MODEL: CCD-TR840E/TR845E
STANDARD B MODEL: CCD-TR311/TR311E/TR411E/TR412E/TR511E/TR512E/TR640E/TR730E
VTR REC MODEL: CCD-TR840E (Australia model)
TBC/AVR MODEL: CCD-TR730E/TR840E/TR845E
TIME CODE MODEL: CCD-TR845E

3-3. VTR/CAMERA CONTROL BLOCK DIAGRAM

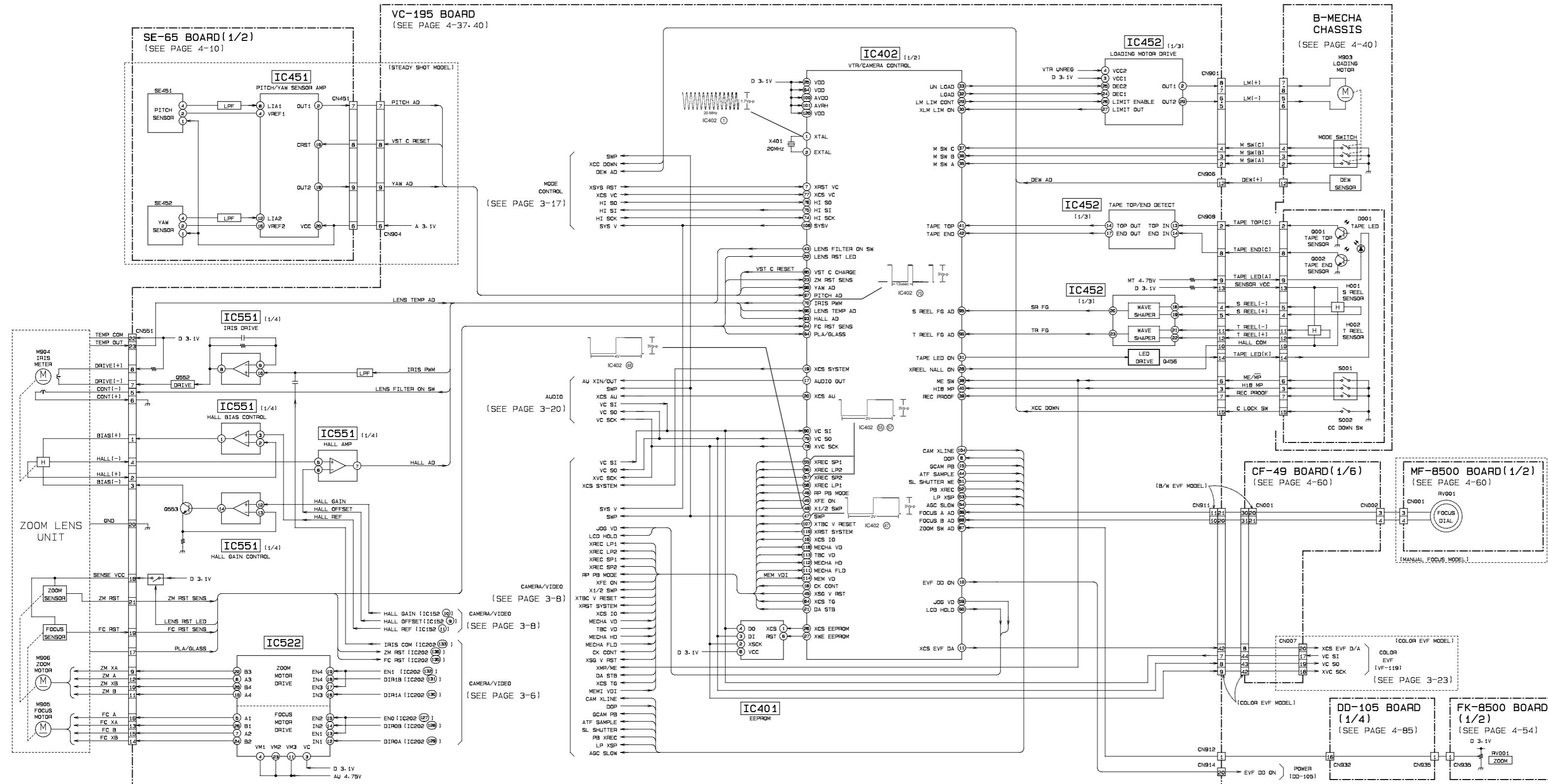

STEADY SHOT MODEL: CCD-TR640E/TR730E/TR840E/TR845E
 COLOR EVF MODEL: CCD-TR512E/TR730E
 MANUAL FOCUS MODEL: CCD-TR511E/TR512E/TR640E/TR730E/TR840E/TR845E

3-4. SERVO BLOCK DIAGRAM

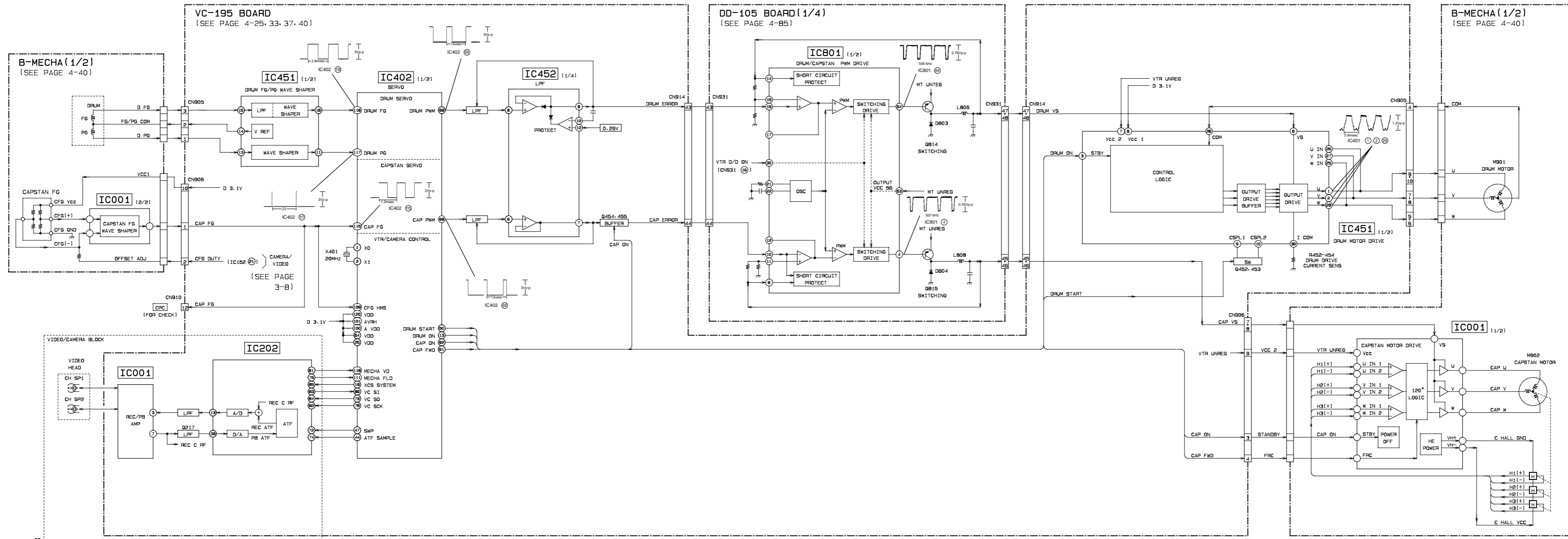

3-5. MODE CONTROL BLOCK DIAGRAM

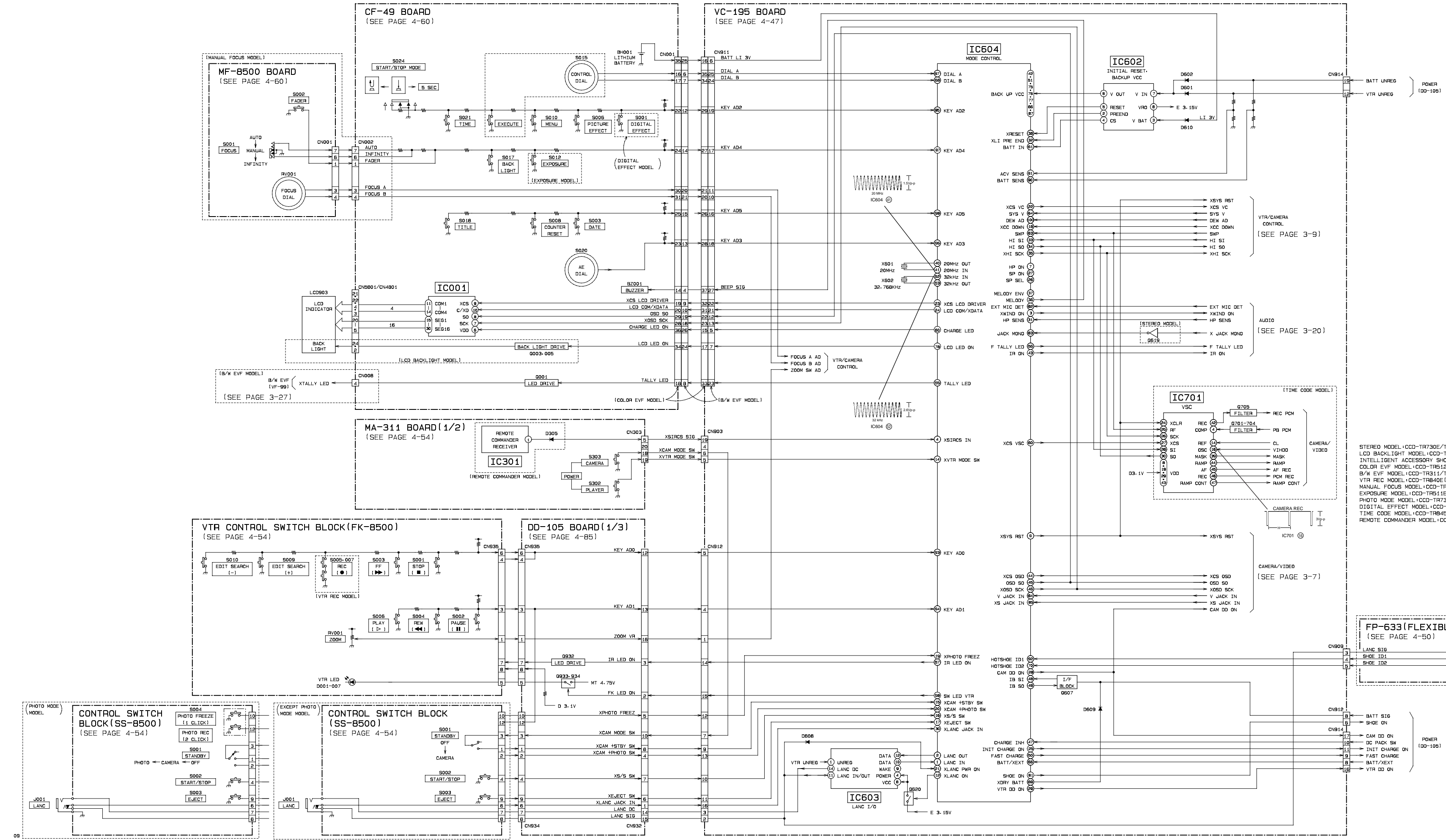

STEREO MODEL: CCD-TR730E/TR840E/TR845E
 LCD BACKLIGHT MODEL: CCD-TR840E/TR845E
 INTELLIGENT ACCESSORY SHOE MODEL: CCD-TR730E/TR840E/TR845E
 COLOR EVF MODEL: CCD-TR311E/TR411E/TR412E/TR511E/TR840E/TR845E
 B/W EVF MODEL: CCD-TR311E/TR311E/TR411E/TR412E/TR511E/TR840E/TR845E
 VTR REC MODEL: CCD-TR840E (AUSTRIAN MODEL)
 MANUAL FOCUS MODEL: CCD-TR311E/TR512E/TR640E/TR730E/TR840E/TR845E
 EXPOSURE MODEL: CCD-TR311E/TR512E/TR640E/TR730E/TR840E/TR845E
 PHOTO MODE MODEL: CCD-TR730E
 DIGITAL EFFECT MODEL: CCD-TR730E
 TIME CODE MODEL: CCD-TR845E
 REMOTE COMMANDER MODEL: CCD-TR412E/TR512E/TR640E/TR730E/TR840E/TR845E

INTELLIGENT ACCESSORY SHOE MODEL
 LANC SIG
 SHOE ID1
 SHOE ID2

3-7. COLOR EVF BLOCK DIAGRAM

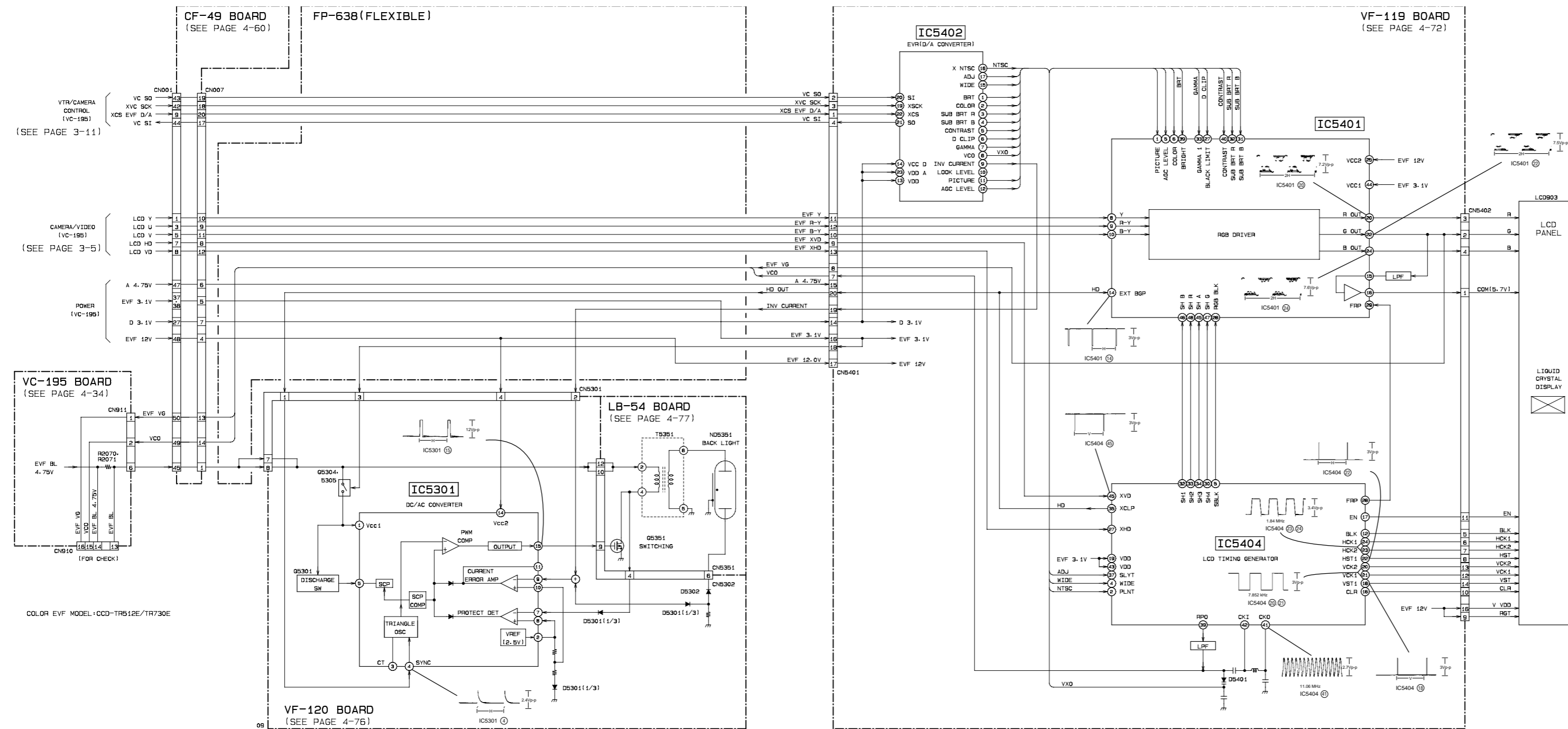

COLOR EVF MODEL: CCD-TR512E/TR730E

3-9. POWER BLOCK DIAGRAM

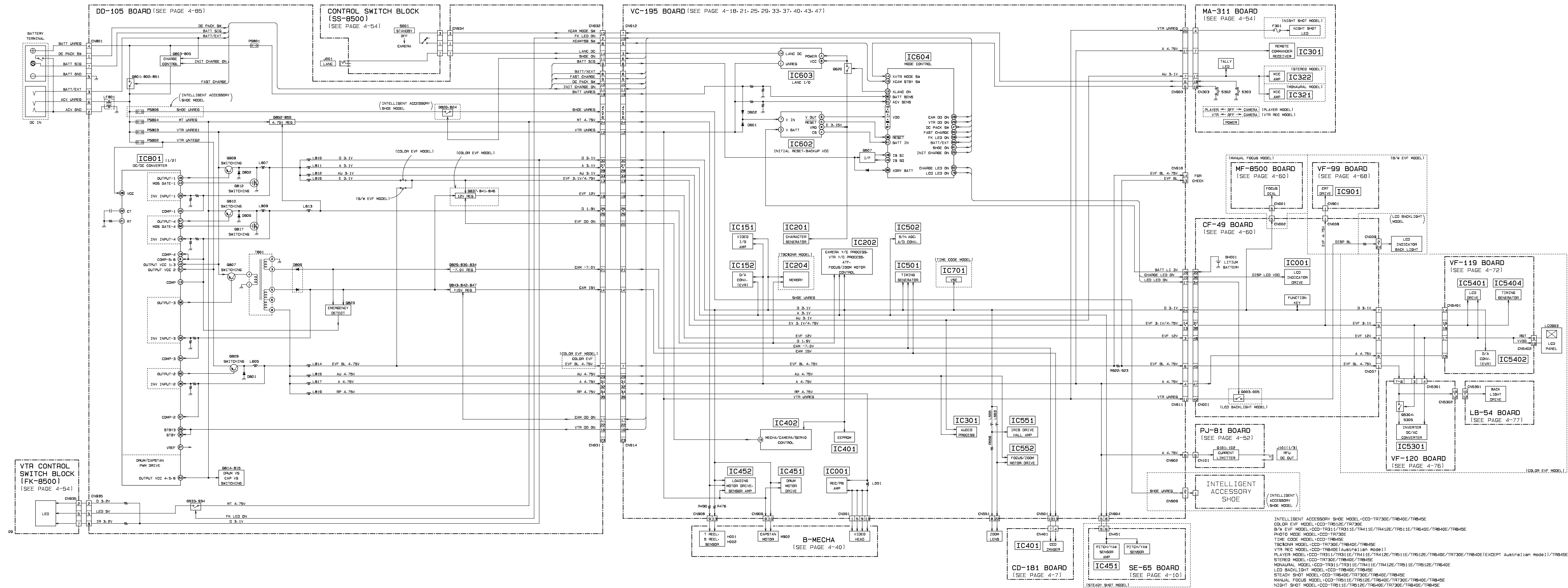

INTELLIGENT ACCESSORY SHOE MODEL: CCD-TR730E/TR840E/TR845E
 CCD OR EVF MODEL: CCD-TR512E/TR730E
 B/W EVF MODEL: CCD-TR311/TR311E/TR411E/TR412E/TR511E/TR640E/TR840E/TR845E
 PHOTO MODEL: CCD-TR730E
 TIME CODE MODEL: CCD-TR845E
 TBC&NR MODEL: CCD-TR730E/TR840E/TR845E
 VTR REC MODEL: CCD-TR840E (Australian model)
 PLAYER MODEL: CCD-TR311/TR311E/TR411E/TR412E/TR511E/TR512E/TR640E/TR730E/TR840E (EXCEPT Australian model)/TR845E
 LCD BACKLIGHT MODEL: CCD-TR840E/TR845E
 STEREO MODEL: CCD-TR730E/TR840E/TR845E
 MONAURAL MODEL: CCD-TR311/TR311E/TR411E/TR412E/TR511E/TR512E/TR640E
 LCD BACKLIGHT MODEL: CCD-TR840E/TR845E
 STEADY SHOT MODEL: CCD-TR840E/TR730E/TR840E/TR845E
 MANUAL FOCUS MODEL: CCD-TR511E/TR512E/TR640E/TR730E/TR840E/TR845E
 NIGHT SHOT MODEL: CCD-TR511E/TR512E/TR640E/TR730E/TR840E/TR845E

SECTION 4
PRINTED WIRING BOARDS AND SCHEMATIC DIAGRAMS

4-1. FRAME SCHEMATIC DIAGRAM

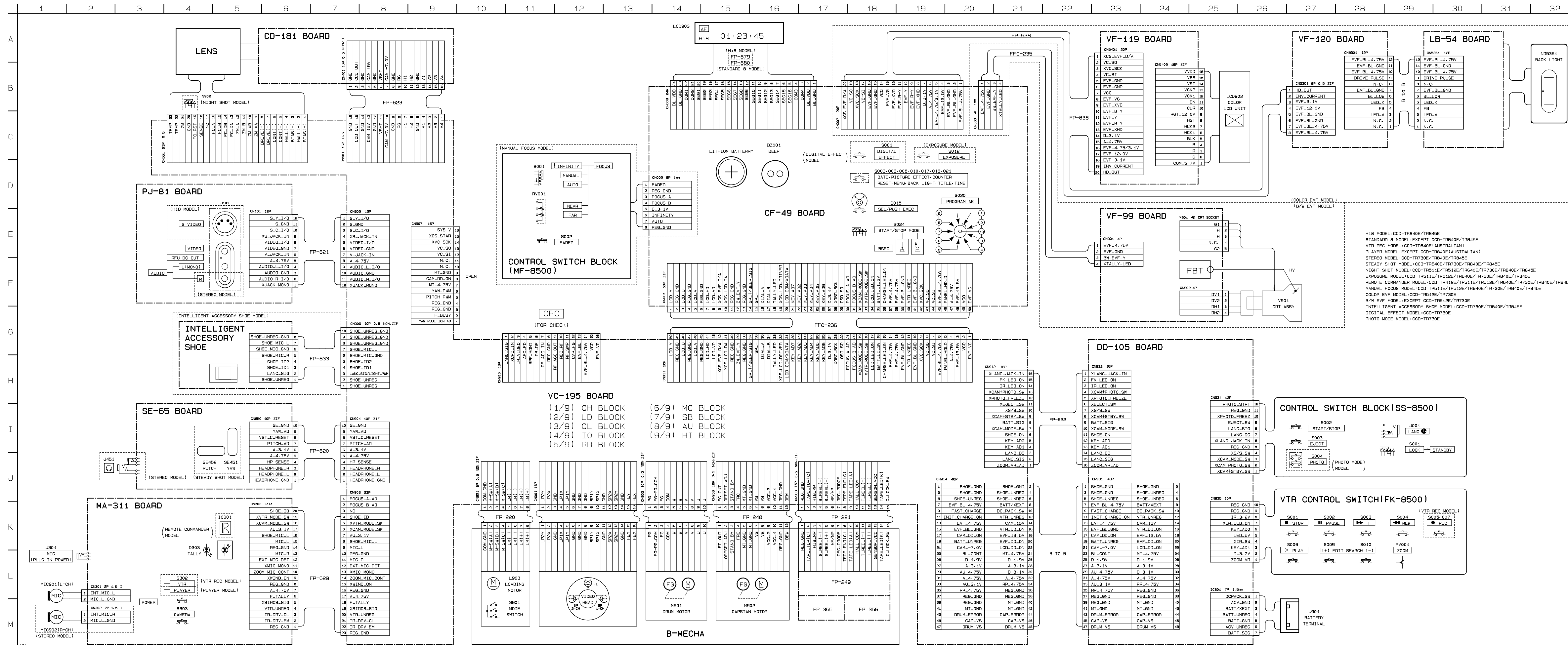

4-2. PRINTED WIRING BOARDS AND SCHEMATIC DIAGRAMS

THIS NOTE IS COMMON FOR PRINTED WIRING BOARDS AND SCHEMATIC DIAGRAMS.
(In addition to this, the necessary note is printed in each block.)

• For printed wiring boards.

- Pattern from the side which enable seeing.
(The other layer's patterns are not indicated.)
- Circled numbers refer to waveforms.
- Through hole is omitted.
- There are few cases that the part printed on diagram isn't mounted in this model.
- Chip parts.

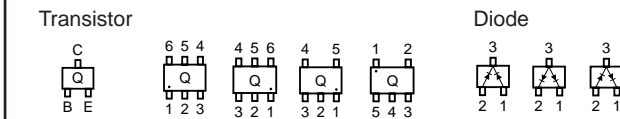

• For schematic diagrams.

- All capacitors are in μF unless otherwise noted. pF: μF .
- 50 V or less are not indicated except for electrolytics and tantalums.
- Chip resistor are 1/16W unless otherwise noted.
- k Ω : 1000 Ω , M Ω : 1000k Ω .
- Caution when replacing chip parts.
New parts must be attached after removal of chip.
Be careful not to heat the minus side of tantalum capacitor, because it is damaged by the heat.
- Some chip part will be indicated as follows.

Example	C541	L452
	22U	10UH
	TA A	2520

Kinds of capacitor Temperature characteristics External dimensions (mm)

- Constants of resistors, capacitors, ICs and etc with XX indicate that they are not used. In such cases, the unused circuits may be indicated.
- Parts with ☆ differ according to the model/destination. Refer to the mount table for each function.
- All variable and adjustable resistors have characteristic curve B, unless otherwise noted.
- Signal name
XEDIT → EDIT PB/XREC → PB/REC
- Flammable resistor symbol: non flammable resistor.
- Fusible resistor symbol: fusible resistor.
- Panel designation symbol: panel designation.
- B+ Line symbol: B+ Line
- B- Line symbol: B- Line
- IN/OUT direction of (+, -) B LINE symbol: IN/OUT direction of (+, -) B LINE.
- Adjustment for repair symbol: adjustment for repair.
- Circled numbers refer to waveforms.

The components identified by mark Δ or dotted line with mark Δ are critical for safety. Replace only with part number specified.

Les composants identifiés par une marque Δ sont critiques pour la sécurité. Ne les remplacer que par une pièce portant le numéro spécifié.

When indicating parts by reference number, please include the board name.

• Measuring conditions voltage value and waveform.

- The object is color bar chart of pattern box.
- Voltages and dc between ground and measurement points. Readings are taken with a digital multimeter (DC 10M Ω).
- Voltages variations may be noted due to normal production tolerances.

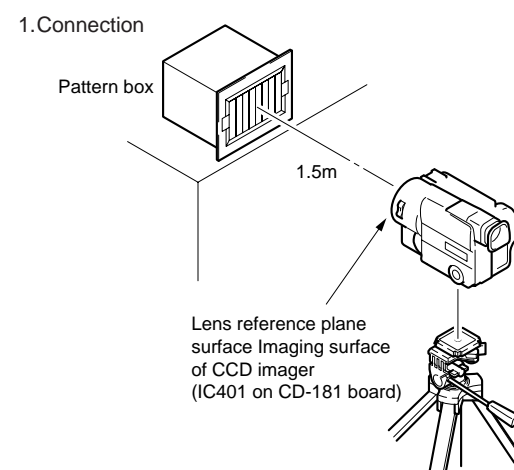

2. Adjust the distance so that the output waveform of Fig. a and the Fig. b can be obtain.

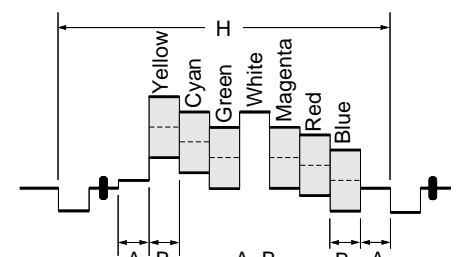

Fig. a (Video output terminal output waveform)

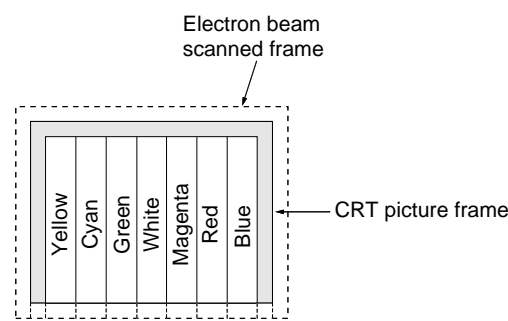
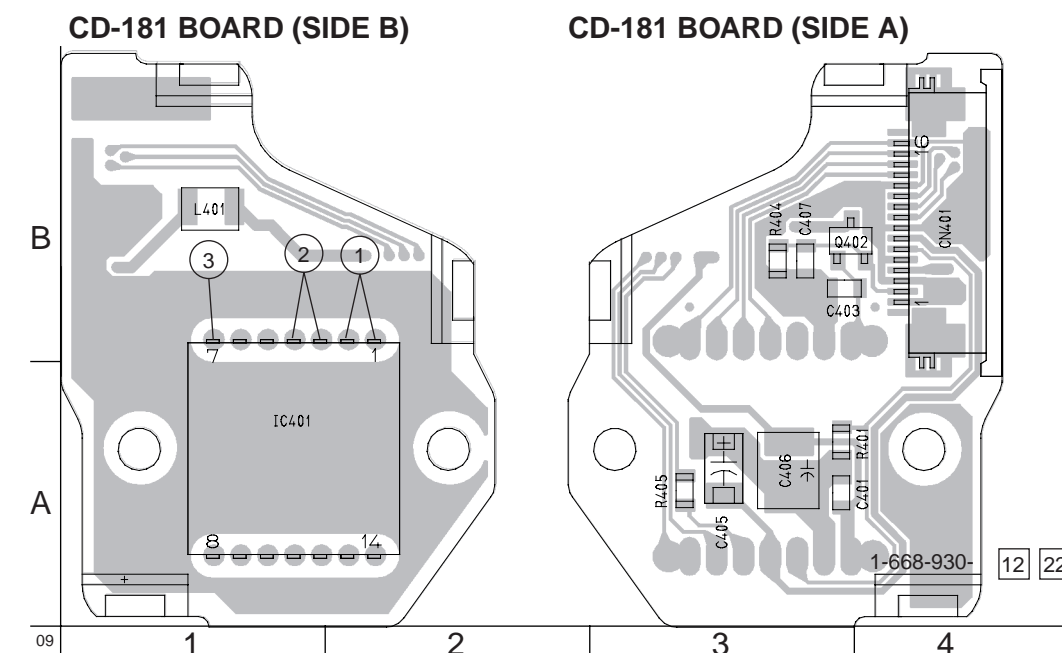

Fig. b (Picture on monitor TV)

CD-181 (CCD IMAGER) PRINTED WIRING BOARD

- Ref No. CD-181 BOARD: 3,000 series -



CD-181 BOARD

C401	A-3
C403	B-3
C405	A-3
C406	A-3
C407	B-3
CN401	B-4
IC401	A-1
L401	B-1
Q402	B-3
R401	A-3
R404	B-3
R405	A-3

• For Printed Wiring Boards.

There are few cases that the part isn't mounted in this diagram is printed on this diagram.

• Chip transistor

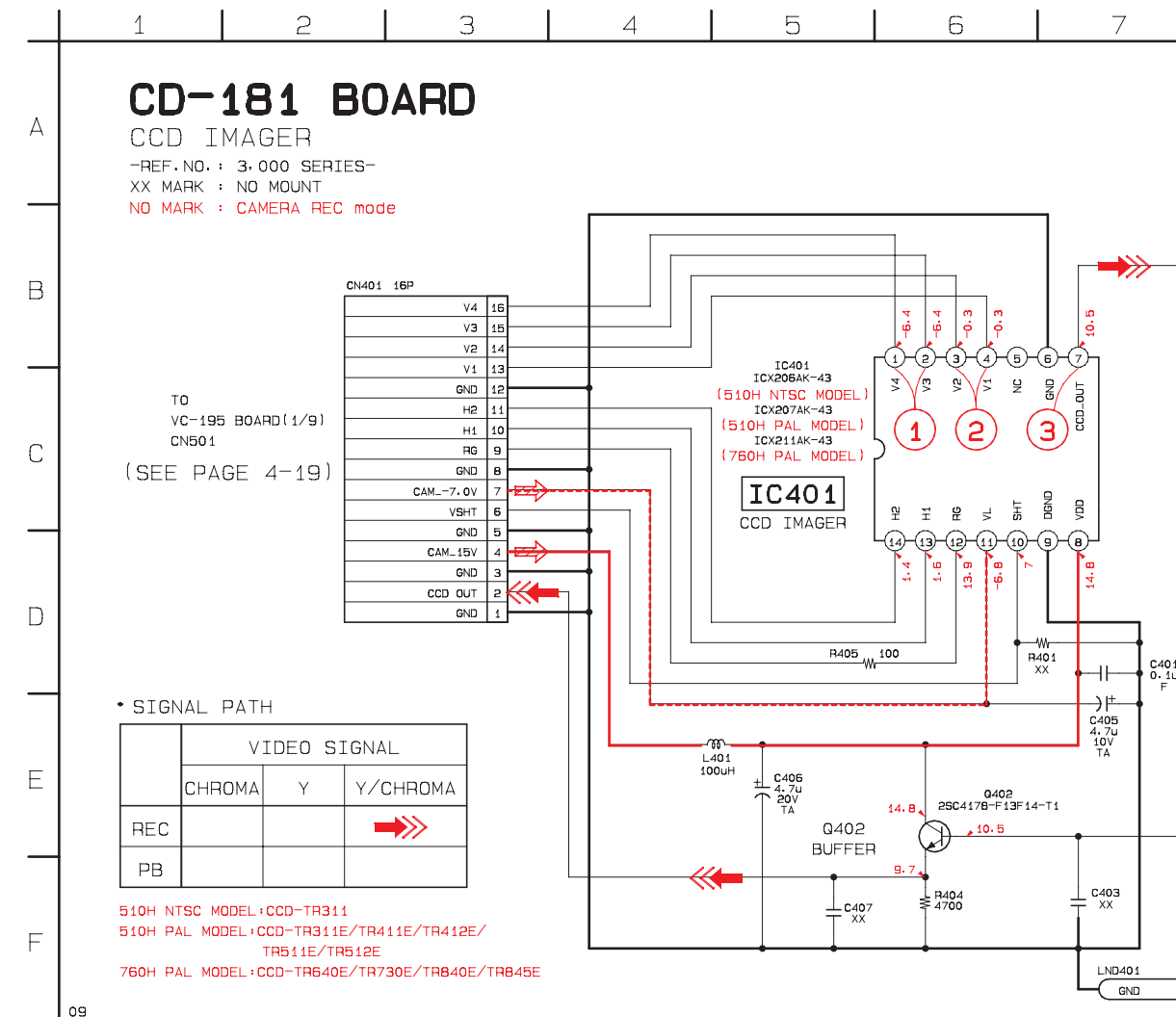
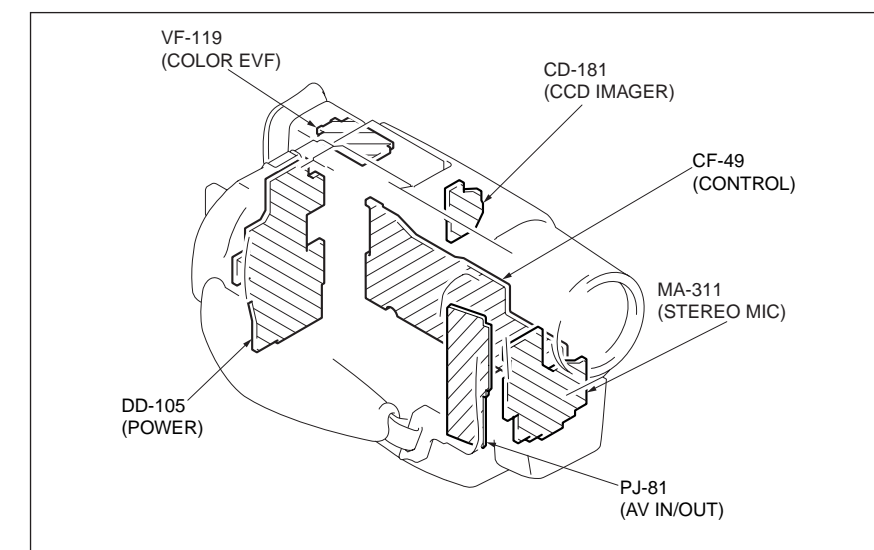
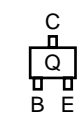

CD-181BOARD CAMERA REC

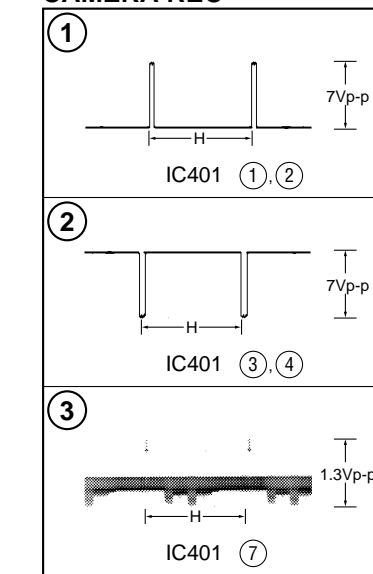

Note on the CCD imager replacement

- The CCD imager is not mounted for the already mounted CD-181 board supplied as the repair parts. When replacing the CD-181 board, remove the CCD imager from the old board and install on the new board.
- Perform all adjustments of the camera block when the CCD imager has been replaced.
- Handle the CCD imager with attention such as MOS IC as it may be broken by static electricity in the structure. Also, prevent the receiving light section from dust attached and strong light.

SE-65 (STEADY SHOT) PRINTED WIRING BOARD

- Ref No. SE-65 BOARD: 3,000 series -

SE-65 BOARD (SIDE B)

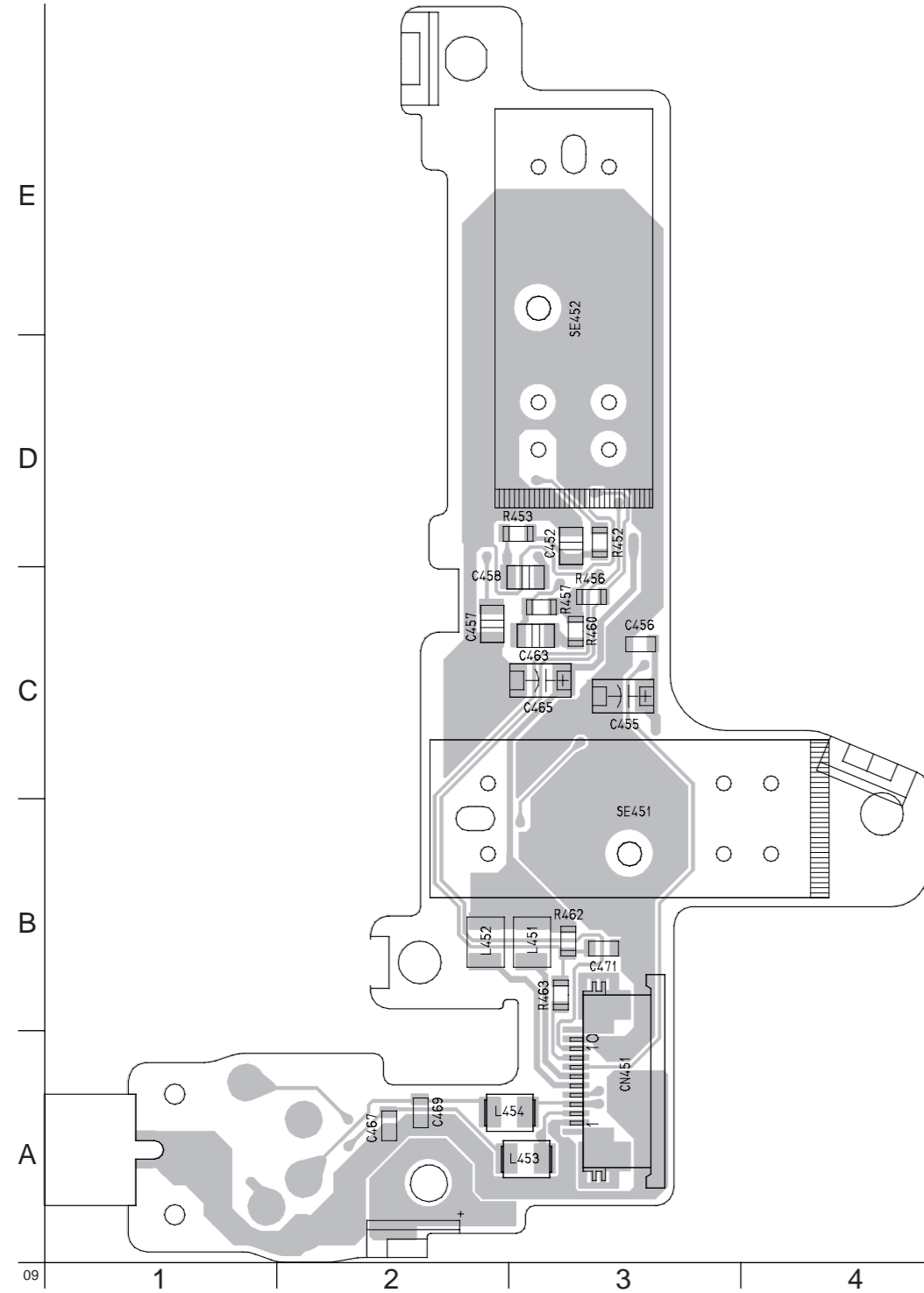

SE-65 BOARD (SIDE A)

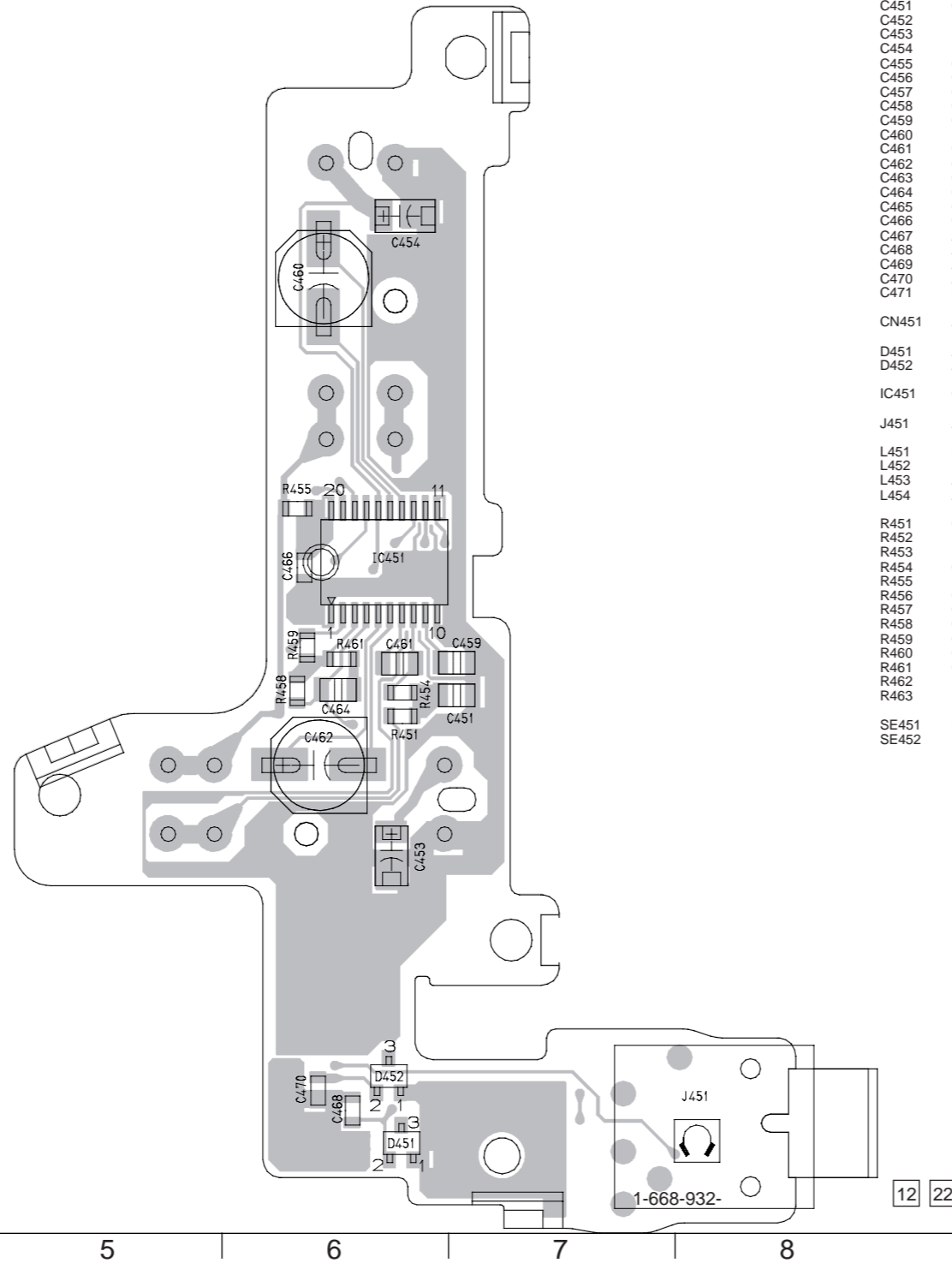

SE-65 BOARD

- C451 C-6
- C452 D-3
- C453 B-6
- C454 E-6
- C455 C-3
- C456 C-3
- C457 C-2
- C458 C-3
- C459 C-6
- C460 F-6
- C461 C-6
- C462 C-6
- C463 C-3
- C464 C-6
- C465 C-3
- C466 C-6
- C467 A-2
- C468 A-6
- C469 A-2
- C470 A-6
- C471 B-3
- CN451 A-3
- D451 A-6
- D452 A-6
- IC451 C-6
- J451 A-8
- L451 B-3
- L452 B-2
- L453 A-3
- L454 A-2
- R451 C-6
- R452 D-3
- R453 D-3
- R454 C-6
- R455 D-6
- R456 C-3
- R457 C-3
- R458 C-6
- R459 C-6
- R460 C-3
- R461 C-6
- R462 B-3
- R463 B-3
- SE451 B-3
- SE452 D-3

SE-65 BOARD (STEADY SHOT MODEL)

STEADY SHOT
-REF. NO. : 3,000 SERIES-
XX MARK : NO MOUNT
NO MARK : CAMERA REC mode

SIGNAL PATH

REC	AUDIO SIGNAL
PB	→

STEREO MODEL : CCD-TR730E/TR840E/TR845E
STEADY SHOT MODEL : CCD-TR640E/TR730E/TR840E/TR845E

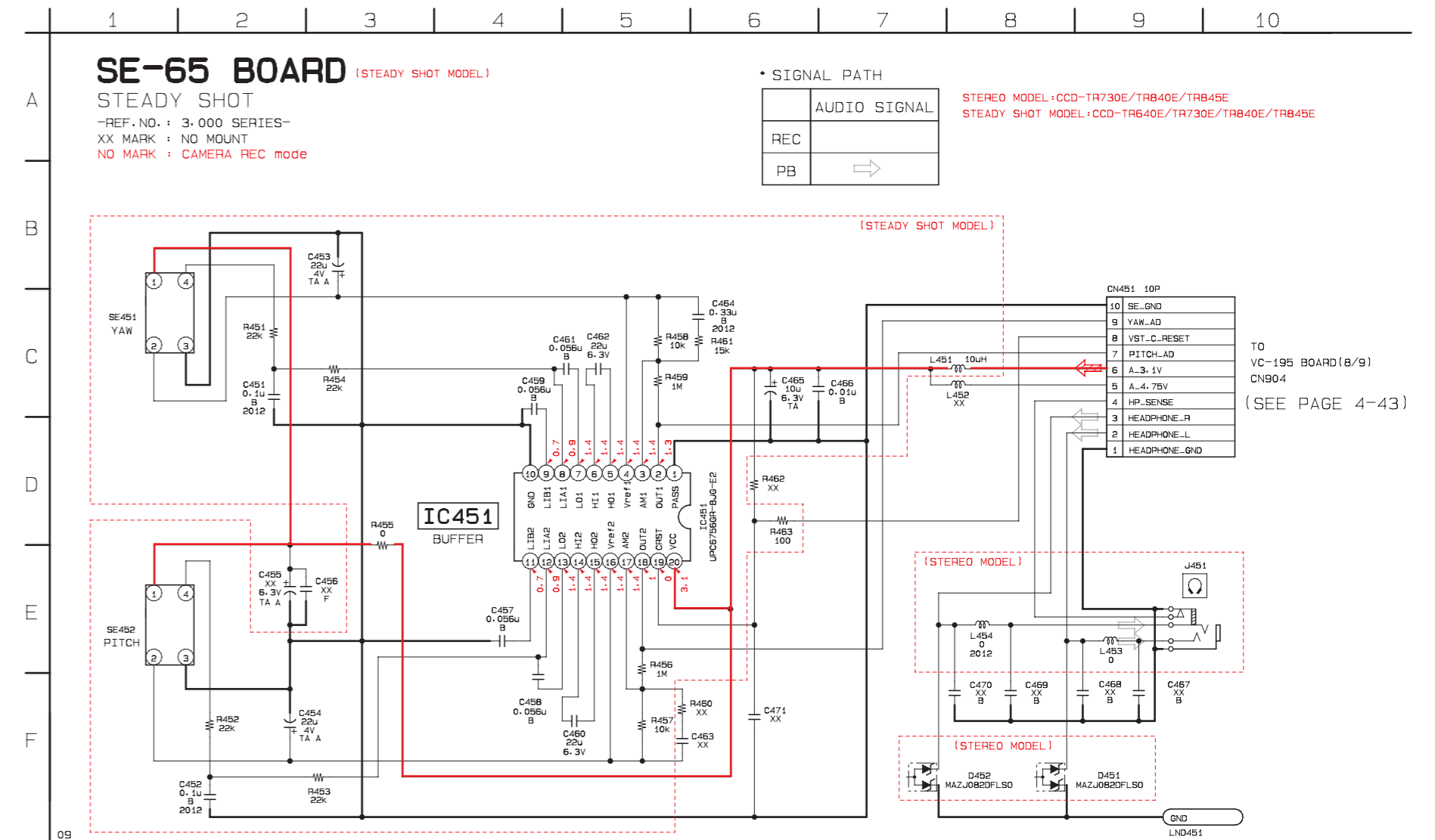

TO VC-195 BOARD (8/9)
CN904
(SEE PAGE 4-43)

• For Printed Wiring Boards.

There are few cases that the part isn't mounted in this model is printed on this diagram.

• Chip diode

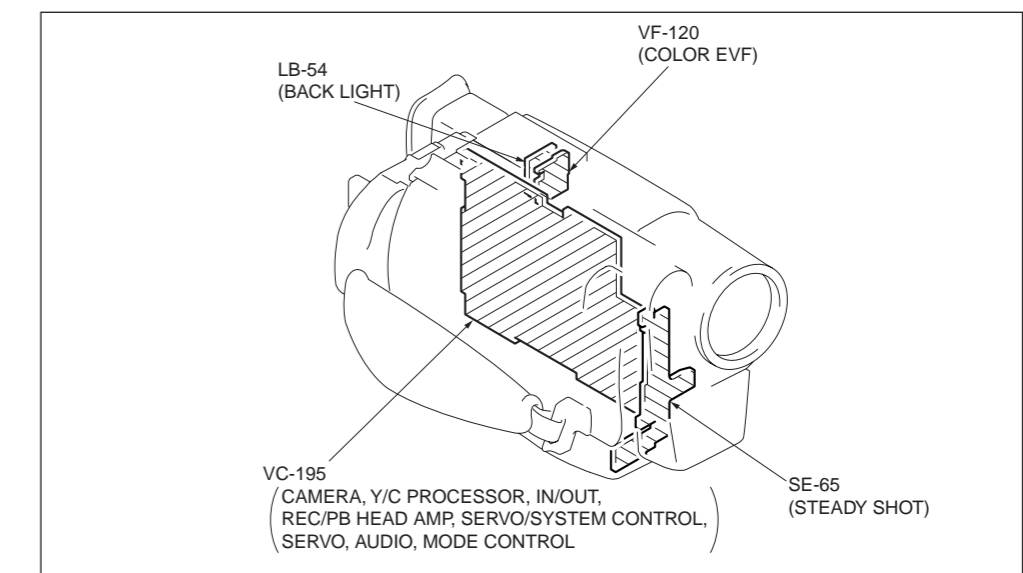

CCD-TR311/TR311E/TR411E/TR412E/TR511E/TR512E/
TR640E/TR730E/TR840E/TR845E

VC-195 (CAMERA, Y/C PROCESSOR, IN/OUT, REC/PB HEAD AMP, SERVO/SYSTEM CONTROL, SERVO, AUDIO, MODE CONTROL) PRINTED WIRING BOARD

- Ref No. VC-195 BOARD: 1,000 series -

VC-195 BOARD
(SIDE B)

C002	A-5	C213	D-5	C481	A-1	C774	A-8	L156	C-7	Q454	A-1	R112	C-7	R428	B-2	R628	E-2	R773	B-8
C003	A-5	C217	D-4	C482	A-2	C775	A-8	L201	D-3	Q455	A-1	R152	D-8	R429	B-1	R629	F-1	R774	B-9
C008	A-4	C218	D-4	C483	A-2	C776	B-8	L202	D-4	Q551	G-7	R154	D-8	R430	B-1	R630	F-2	R775	A-8
C009	B-5	C227	D-5	C484	A-2	C777	A-8	L203	D-6	Q607	F-2	R157	D-8	R432	C-2	R631	G-2	R921	B-1
C011	B-5	C229	E-5	C485	A-1	C778	B-8	L204	D-4	Q619	E-3	R179	D-8	R433	C-2	R632	G-1	R922	D-1
C012	B-5	C232	D-3	C504	E-6	C781	B-8	L205	D-6	Q620	F-2	R180	D-8	R434	C-2	R633	E-2	R923	D-1
C013	B-5	C233	D-5	C505	E-6			L206	D-3	Q705	F-7	R183	E-8	R452	A-3	R634	E-2	R924	D-1
C014	B-5	C234	D-5	C506	E-6	CN904	A-9	L207	E-4			R184	E-8	R453	A-3	R635	E-2	R925	D-1
C015	B-5	C235	D-6	C507	E-6	CN907	D-9	L209	E-4	RO01	A-6	R202	D-3	R454	A-3	R636	E-2	R926	G-7
C016	B-5	C236	D-3	C508	E-6	CN910	D-1	L402	C-2	RO02	A-6	R203	D-4	R455	A-3	R637	G-2	R927	G-7
C017	B-5	C239	E-4	C509	E-7			L501	E-6	RO08	A-4	R204	D-3	R456	A-3	R638	G-2		
C019	B-5	C241	E-3	C510	E-6	D001	C-4	L552	F-7	RO09	A-5	R205	D-3	R457	A-3	R639	G-2	RB12	C-8
C020	B-5	C243	F-3	C514	E-5	D201	D-3	L553	G-7	RO10	B-6	R206	D-4	R459	A-3	R640	F-2	RB151	C-8
C022	B-5	C244	F-3	C515	E-5	D202	D-3	L602	E-3	RO11	B-5	R208	D-3	R460	A-3	R641	F-2		
C025	B-6	C245	D-4	C518	F-5	D371	E-8	L701	F-7	RO12	B-5	R210	D-3	R461	A-3	R642	F-2	TH401	B-4
C038	B-6	C246	D-4	C553	G-6	D502	F-5	L702	F-7	RO13	B-6	R211	D-3	R462	A-3	R643	F-2		
C040	B-6	C247	D-4	C554	G-7	D601	E-2	L704	F-8	RO14	B-4	R212	D-6	R463	A-3	R644	F-2		
C042	B-5	C249	E-4	C556	G-7	D602	E-2	L751	B-8	RO15	B-5	R214	D-5	R467	A-2	R645	E-2		
C043	B-5	C252	F-3	C557	G-5	D604	F-2	L752	B-8	RO16	B-6	R215	D-5	R468	A-2	R646	F-2		
C048	B-6	C301	B-9	C558	G-5	D608	F-1	L753	B-8	RO17	B-6	R216	D-5	R469	A-2	R647	F-2		
C050	C-6	C312	C-9	C559	F-7	D609	F-2			RO18	B-5	R217	E-4	R470	A-2	R648	F-2		
C051	B-5	C371	E-8	C563	F-6	D611	E-2	Q003	A-5	RO19	B-5	R223	D-3	R471	A-2	R649	F-2		
C054	B-5	C372	E-8	C564	F-7	D910	G-1	Q004	A-6	RO20	B-4	R224	D-3	R472	A-3	R651	F-2		
C056	C-6	C378	F-7	C566	G-7			Q005	A-5	RO21	B-5	R226	D-4	R473	A-1	R652	F-3		
C058	B-6	C380	E-7	C568	G-7			Q006	A-5	RO22	B-5	R228	D-4	R475	A-1	R653	F-3		
C060	C-5	C381	E-7	C572	F-6	FB203	E-4	Q007	A-6	RO25	B-6	R244	D-3	R477	A-2	R654	F-3		
C066	B-6	C382	F-8	C603	F-1	FB204	F-3	Q008	B-6	RO29	B-5	R246	D-3	R479	A-2	R655	F-2		
C067	C-6	C383	F-8	C607	E-2	FB205	F-3	Q009	B-6	RO31	B-5	R247	D-3	R480	A-2	R662	E-3		
C068	C-6	C384	E-8	C610	F-2	FB206	D-4	Q010	B-5	RO40	B-5	R248	E-3	R481	A-2	R663	F-3		
C069	C-6	C385	E-8	C611	F-2	FB207	D-4	Q011	B-5	RO41	B-5	R249	E-3	R482	A-2	R665	F-3		
C070	C-6	C387	F-8	C613	E-1	FB202	E-6	Q012	B-5	RO42	B-5	R250	F-3	R483	A-1	R678	F-3		
C072	C-6	C388	E-8	C625	E-2	FB503	E-5	Q016	B-5	RO47	B-5	R254	D-1	R484	A-1	R686	E-2		
C074	C-6	C402	C-1	C626	E-2	FB504	E-5	Q017	B-6	RO48	B-5	R255	E-5	R485	A-1	R687	E-2		
C076	C-5	C413	B-2	C627	F-2	FB505	E-5	Q018	C-5	RO49	B-6	R257	D-4	R486	B-1	R689	F-3		
C077	C-5	C451	A-3	C630	F-3	FB506	E-5	Q019	C-6	RO50	B-6	R304	B-9	R487	A-1	R690	F-2		
C080	C-5	C452	A-3	C631	F-3			Q021	C-6	RO51	B-6	R305	A-6	R488	A-1	R691	E-2		
C083	C-5	C453	A-3	C636	F-2	IC152	C-8	Q023	C-6	RO56	B-6	R329	A-6	R505	E-6	R692	F-1		
C086	C-4	C454	A-3	C704	F-7	IC201	E-5	Q025	C-6	RO58	B-6	R330	A-7	R508	E-5	R704	G-8		
C087	C-4	C455	A-3	C714	F-8	IC204	F-4	Q026	C-6	RO66	B-6	R371	D-8	R510	E-5	R705	G-8		
C090	C-6	C456	A-4	C715	F-8	IC371	E-7	Q030	C-5	RO67	C-6	R372	D-8	R511	E-5	R716	G-7		
C152	D-8	C457	A-3	C751	B-6	IC401	C-2	Q031	C-5	RO68	C-7	R373	D-9	R512	F-5	R717	F-8		
C157	E-8	C458	A-4	C752	A-7	IC403	B-2	Q032	C-7	RO69	C-6	R374	D-8	R527	F-5	R718	F-7		
C158	D-8	C459	A-4	C753	A-7	IC404	B-2	Q035	C-4	RO69	C-6	R375	D-8	R552	G-6	R719	F-8		
C159	C-8	C460	A-4	C754	A-7	IC451	A-4	Q037	C-4	RO70	C-6	R376	D-8	R555	G-7	R723	F-7		
C174	D-8	C461	A-3	C755	A-7	IC452	A-2	Q038	C-5	RO76	C-6	R377	E-8	R563	G-5	R752	A-7		
C175	D-8	C462	A-4	C756	A-7	IC501	E-6	Q039	C-5	RO77	C-6	R378	E-8	R564	G-6	R753	A-7		
C176	D-8	C463	A-3	C757	A-7	IC552	G-6	Q041	B-5	RO78	C-6	R379	E-7	R566	G-5	R754	B-6		
C182	D-8	C464	B-3	C758	A-8	IC602	E-2	Q042	C-4	RO79	C-6	R382	E-8	R567	G-6	R755	B-6		
C183	D-8	C465	B-4	C759	B-6	IC751	A-8	Q151	D-8	RO80	C-6	R383	E-8	R570	F-5	R757	A-7		
C190	D-8	C466	B-3	C760	B-6			Q202	D-3	RO83	C-5	R384	E-7	R579	G-6	R758	A-7		
C191	C-7	C467	B-3	C761	B-8	L002	B-4	Q203	D-3	RO84	C-5	R385	F-8	R582	G-6	R759	A-7		
C192	C-7	C468	B-3	C762	B-8	L003	B-4	Q204	D-5	RO87	C-5	R386	F-8	R603	F-2	R760	B-8		
C202	D-3	C469	B-4	C763	B-8	L007	C-6	Q205	F-5	RO88	C-5	R386	F-8	R604	F-2	R761	A-8		
C203	D-3	C470	B-4	C764	B-8	L008	C-6	Q208	D-6	RO90	C-5	R388	E-8	R608	F-2	R762	A-8		
C204	D-4	C471	B-4	C765	A-8	L010	C-6	Q217	D-4	RO94	C-5	R389	E-8	R612	E-1	R763	A-8		
C205	E-4	C473	A-1	C766	A-8	L011	C-6	Q218	D-4	RO95	C-7	R403	C-2	R618	F-1	R764	B-8		
C206	D-4	C474	A-2	C767	B-8	L014	C-5	Q306	B-9	RO97	C-5	R404	C-3	R619	F-1	R765	B-8		
C207	D-3	C475	A-2	C768	B-8	L015	C-5	Q307	C-9	R100	C-5	R415	B-2	R620	F-1	R766	A-8		
C208	D-3	C476	A-2	C769	A-8	L017	C-5	Q311	A-6	R104	C-5	R416	B-2	R621	F-1	R767	B-9		
C209	D-6	C477	A-2	C770	A-8	L019	B-6	Q312	A-7	R105	C-6	R417	B-2	R622	F-2	R768	A-8		
C210	D-6	C478	A-2	C771	B-8	L152	D-8	Q451	B-3	R106	C-6	R418	B-2	R624	F-1	R770	A-8		
C211	D-3	C479	A-2	C772	A-8	L153	D-7	Q452	B-4	R109	B-4	R426	C-2	R625	F-2	R771	A-8		
C212	D-3	C480	A-2	C773	B-8	L154	D-7	Q453	B-4	R110	B-5	R427	B-2	R627	E-2	R772	A-8		

VC-195 BOARD (SIDE B)

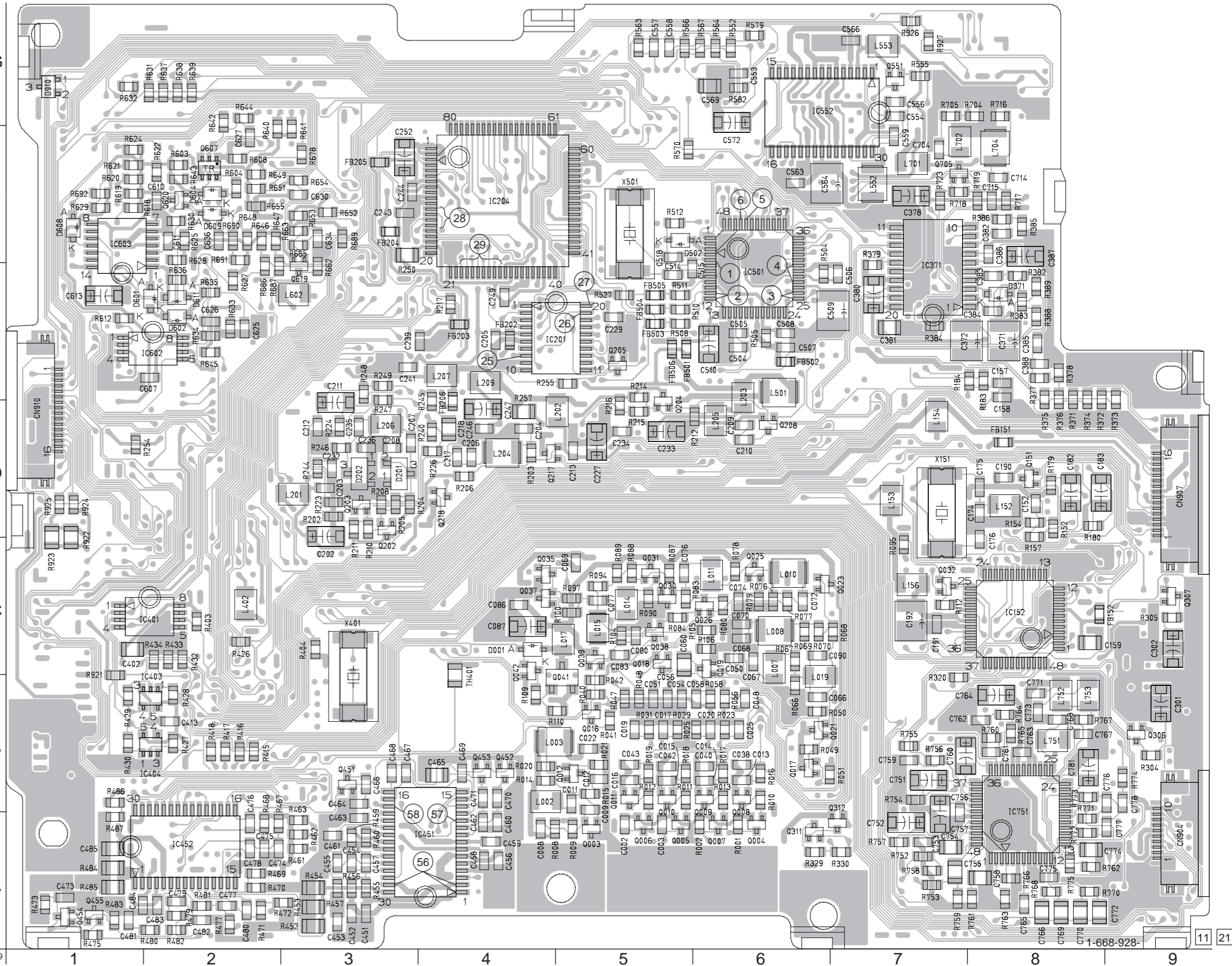

CCD-TR311/TR311E/TR411E/TR412E/TR511E/TR512E/
TR640E/TR730E/TR840E/TR845E

VC-195 BOARD (SIDE A)

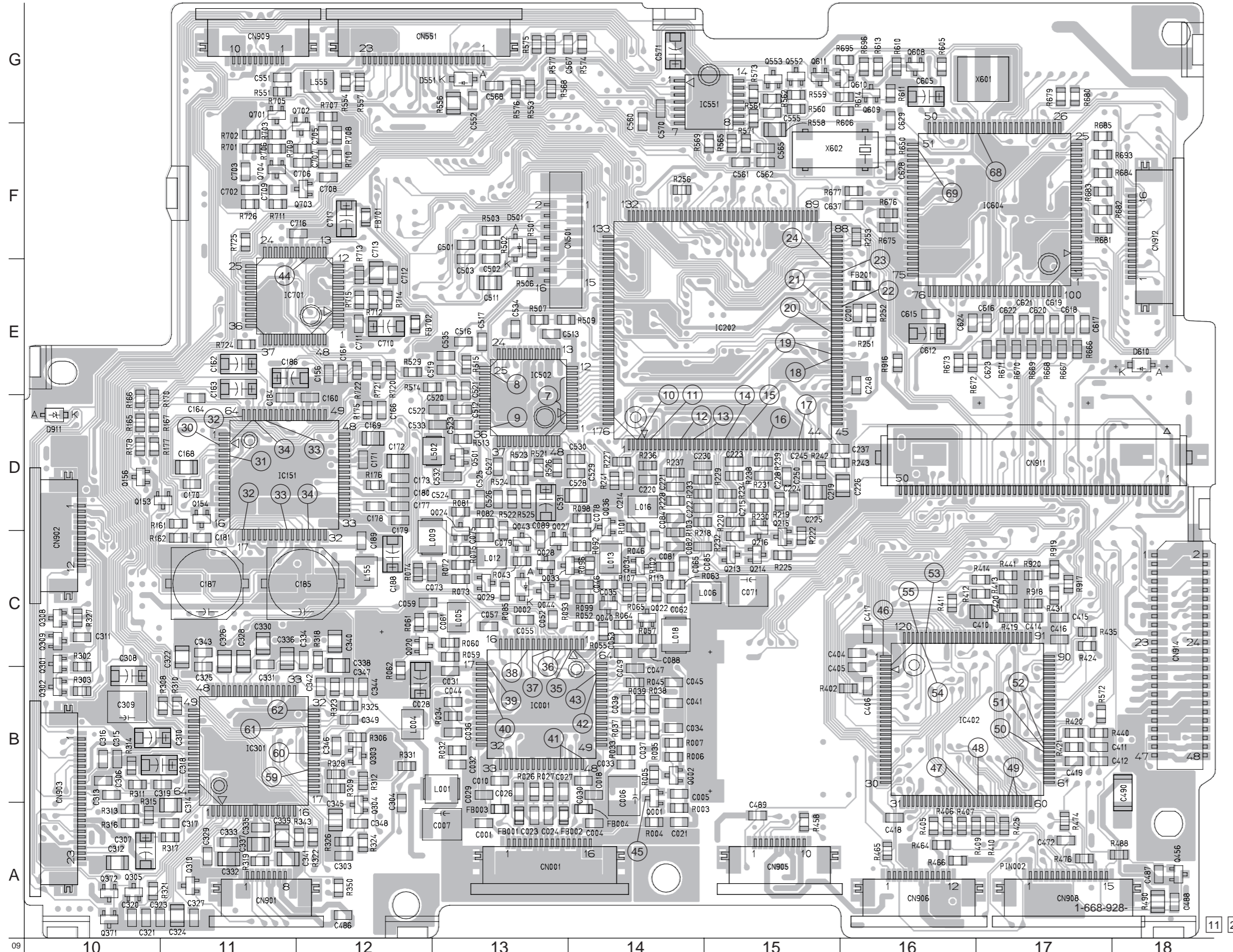

VC-195 BOARD
(SIDE A)

C001	A-13	C328	C-11	CN908	A-17	R074	C-12	R527	B-17
C004	A-14	C330	C-11	CN909	G-11	R075	C-13	R529	E-12
C005	B-13	C331	C-11	CN910	D-17	R081	C-13	R531	G-11
C006	B-14	C332	A-11	CN912	F-18	R082	D-13	R532	G-15
C007	A-13	C333	A-11	CN914	B-18	R085	C-13	R533	G-13
C010	B-13	C334	C-12			R092	C-14	R534	G-12
C018	B-14	C335	A-11	D002	C-13	R093	C-13	R535	G-13
C021	A-14	C336	C-11	D501	F-13	R096	C-14	R537	G-12
C022	A-13	C337	A-11	D502	G-13	R098	A-11	R538	F-15
C023	A-13	C338	B-12	D610	E-18	R099	C-14	R539	G-15
C024	A-13	C339	A-11	D911	D-10	R101	D-14	R560	G-15
C026	B-13	C340	C-12			R102	C-14	R561	G-15
C027	B-13	C341	A-11	FB001	A-13	R103	C-14	R562	G-15
C028	B-12	C342	B-12	FB002	A-13	R107	C-14	R565	F-15
C029	B-14	C343	B-12	FB003	A-13	R113	C-14	R568	G-13
C030	B-14	C344	B-12	FB004	A-14	R161	D-11	R569	F-15
C031	B-13	C345	A-12	FB201	E-16	R162	C-11	R571	F-15
C032	B-13	C346	B-12	FB701	F-12	R165	D-10	R573	G-15
C033	B-14	C347	B-12	FB702	E-12	R166	D-10	R574	G-14
C034	B-14	C348	A-12			R167	D-10	R575	G-13
C035	C-14	C349	B-12	IC001	B-13	R170	D-10	R576	G-13
C036	B-13	C404	C-16	IC151	D-11	R175	D-12	R577	G-13
C037	B-14	C405	B-16	IC202	E-15	R176	D-12	R605	G-16
C039	B-14	C406	B-16	IC301	B-11	R177	D-10	R606	G-16
C041	B-14	C410	C-17	IC402	B-16	R178	D-10	R610	G-16
C045	B-16	C411	B-13	IC502	D-13	R218	D-11	R611	G-16
C046	C-14	C412	B-17	IC551	G-15	R219	D-15	R613	G-16
C047	B-14	C414	C-17	IC701	E-11	R220	D-15	R614	G-16
C049	C-14	C415	C-17			R222	C-15	R650	F-16
C052	C-13	C416	C-17	L001	B-13	R225	C-15	R666	E-17
C053	C-14	C417	C-16	L004	B-12	R227	D-14	R667	E-17
C055	C-13	C418	A-16	L005	C-13	R228	D-14	R668	E-17
C057	C-13	C419	B-17	L006	C-15	R229	D-14	R669	E-17
C059	C-12	C420	C-17	L009	C-13	R230	D-15	R670	E-17
C061	C-13	C472	A-17	L012	C-13	R231	D-15	R671	E-17
C062	C-14	C486	A-12	L013	C-14	R232	C-15	R672	E-16
C065	C-13	C487	A-13	L016	C-13	R233	D-14	R673	E-16
C071	C-15	C488	A-18	L018	C-14	R234	D-15	R675	F-16
C073	C-13	C489	A-15	L155	C-12	R236	D-14	R676	F-16
C075	C-13	C490	B-18	L502	D-13	R237	D-14	R679	G-17
C078	C-14	C501	F-13	L555	G-12	R238	D-15	R680	G-17
C079	C-13	C502	E-13			R239	D-15	R681	F-17
C081	C-13	C503	R241	Q001	B-14	R242	D-14	R682	F-17
C082	C-14	C511	E-13	Q002	B-14	R243	D-15	R683	F-17
C084	D-14	C512	D-13	Q020	C-12	R244	D-16	R684	F-17
C085	C-14	C513	E-13	Q022	C-14	R251	E-16	R685	F-17
C088	C-14	C516	E-13	Q024	C-13	R252	E-16	R693	F-17
C089	C-13	C517	E-13	Q027	C-13	R253	F-16	R695	G-16
C156	D-12	C519	C-13	Q028	C-13	R256	F-14	R696	G-16
C160	D-12	C520	E-13	Q029	C-13	R302	C-10	R701	F-11
C161	E-12	C521	E-13	Q033	C-14	R303	B-10	R702	F-11
C162	E-11	C522	D-13	Q034	C-14	R306	B-12	R703	F-11
C163	E-11	C523	D-13	Q036	D-14	R308	B-11	R706	F-11
C164	D-14	C524	D-14	Q040	C-14	R309	B-12	R707	G-12
C166	D-12	C525	D-13	Q043	C-13	R310	B-11	R708	F-12
C168	D-11	C526	D-13	Q044	C-13	R311	B-10	R709	F-12
C169	D-12	C527	D-13	Q153	D-11	R312	B-12	R710	F-12
C170	D-11	C528	D-14	Q154	D-11	R313	A10	R711	F-11
C171	D-12	C529	D-14	Q156	D-10	R314	B-10	R712	E-12
C172	D-12	C530	D-13	Q159	D-13	R315	A10	R713	E-12
C173	D-12	C531	D-13	Q214	C-15	R316	A10	R714	E-12
C177	D-12	C532	D-13	Q215	C-15	R317	A-11	R715	E-12
C178	D-12	C533	D-13	Q216	C-15	R318	C-12	R720	E-12
C179	D-12	C534	E-13	Q301	C-10	R319	A-11	R721	E-12
C180	D-12	C535	E-13	Q302	B-10	R321	A10	R722	E-12
C181	C-11	C536	C-12	Q303	B-12	R322	A-12	R724	E-11
C184	D-11	C552	G-13	Q304	A-12	R323	B-12	R725	F-11
C185	E-12	C555	G-15	Q305	A10	R325	B-12	R726	F-11
C186	E-11	C560	F-14	Q308	C-10	R326	A-12	R916	E-16
C187	C-11	C561	F-15	Q309	C-10	R327	C-1	R917	C-17
C188	C-12	C562	F-15	Q310	A-11	R328	B-12	R918	C-17
C189	E-13	C565	F-15	Q329	A-11	R331	B-12	R919	C-17
C201	E-16	C567	G-14	Q371	A10	R343	A-12	R920	C-17
C214	D-14	C568	G-13	Q372	A10	R350	A-12		
C215	D-15	C570	G-14	Q456	A-18	R402	B-16	X601	G-17
C219	D-15	C571	G-14	Q501	D-13	R405	A-16	X602	F-15
C220	D-14	C604	F-17	Q53	G-15	R406	A-16		
C221	D-14	C605	G-16	Q608	G-16	R407	A-16		
C222	D-14	C612	E-16	Q609	G-16	R409	A-16		
C223	D-15	C615	E-16	Q610	G-16	R410	A-17		
C224	D-15	C616	E-17	Q611	G-15	R411	C-16		
C225	D-15	C617	E-17	Q702	G-11	R412	C-17		
C226	D-16	C618	D-17	Q703	F-12	R413	C-17		
C228	D-15	C619	E-17	Q704	F-11	R414	C-17		
C230	D-14	C620	E-17	Q704	F-11	R419	C-17		
C237	D-16	C621	E-17			R420	B-17		
C245	D-15	C622	E-17	R003	A-14	R421	B-17		
C248	E-16	C623	E-17	R024	C-17	R424	A-17		
C300	A-12	C624	F-16	R005	B-14	R425	A-17		
C303	A-12	C628	F-16	R006	B-14	R431	C-17		
C304	A-12	C629	F-16	R007	B-14	R435	C-17		
C306	B-10	C637	F-16	R026	B-13	R440	B-17		
C307	A-10	C702	F-11	R027	B-13	R441	C-17		
C308	B-10	C703	F-11	R032	B-13	R458	A-15		
C309	B-10	C705	F-12	R033	B-14	R464	A-16		
C310	B-10	C706	F-12	R034	B-13	R465	A-16		
C311	C-10	C707	F-12	R035	B-14	R466	A-16		
C312	A-10	C708	F-12	R037	B-14	R474	A-17		
C313	B-10	C709	F-11	R038	B-14	R476	A-17		
C314	B-10	C710	A-11	R039	B-14	R488	A-18		
C315	B-10	C711	E-12	R043	C-13	R490	A-18		
C316	B-10	C712	E-12	R045	B-14	R501	F-13		
C317	A-11	C713	E-12	R046	C-14	R502	F-13		
C318	B-10	C716	F-12	R052	C-14	R503	F-13		
C319	B-10	C717	F-12	R057	C-14	R507	E-13		
C320	A-10			R057	C-14	R509	E-13		
C321	A-10	CN001	A-13	R059	C-13	R513	D-13		
C322	C-11	CN501	F-14	R060	C-13	R514	E-13		
C323	A-11	CN551	G-12	R062	B-12	R521	D-13		
C324	A-11	CN501	A-11	R063	C-14	R522	D-13		
C324	A-12	CN902	C-10	R064	C-14	R523	D-13		
C325	C-11	CN903	B-10	R065	C-14	R524	D-13		
C326	C-11	CN905	A-15	R072	C-13	R525	D-13		
C327	A-11	CN906	A-16	R073	C-13	R526	D-13		

4-15

4-16

CCD-TR311/TR311E/TR411E/TR412E/TR511E/TR512E/
TR640E/TR730E/TR840E/TR845E

- For schematic diagrams.
- Refer to page 4-13 for Printed Wiring Board.

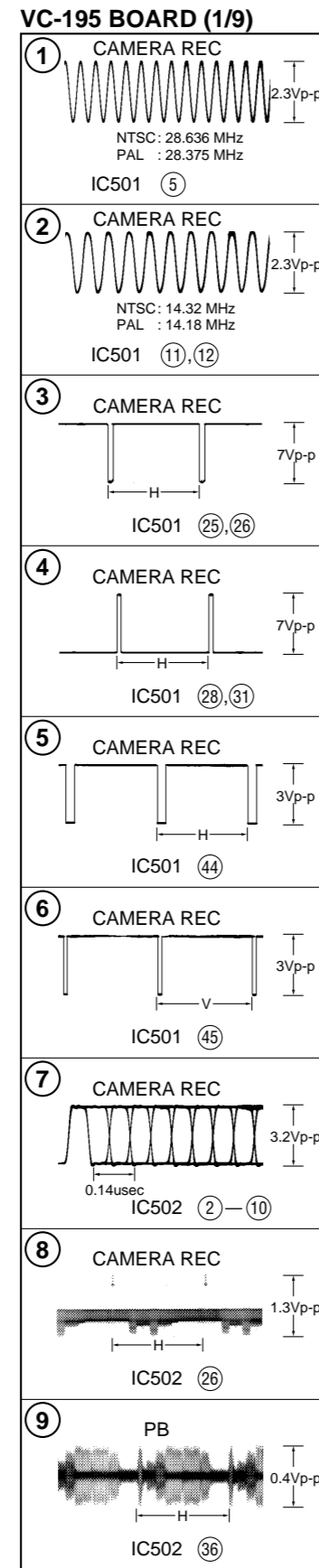

VC-195 BOARD (1/9)

CAMERA1 (CH BLOCK)
-REF. NO.: 1-000 SERIES-
XX MARK: NO MOUNT
NO MARK: CAMERA REC mode
*: Can not be measured.

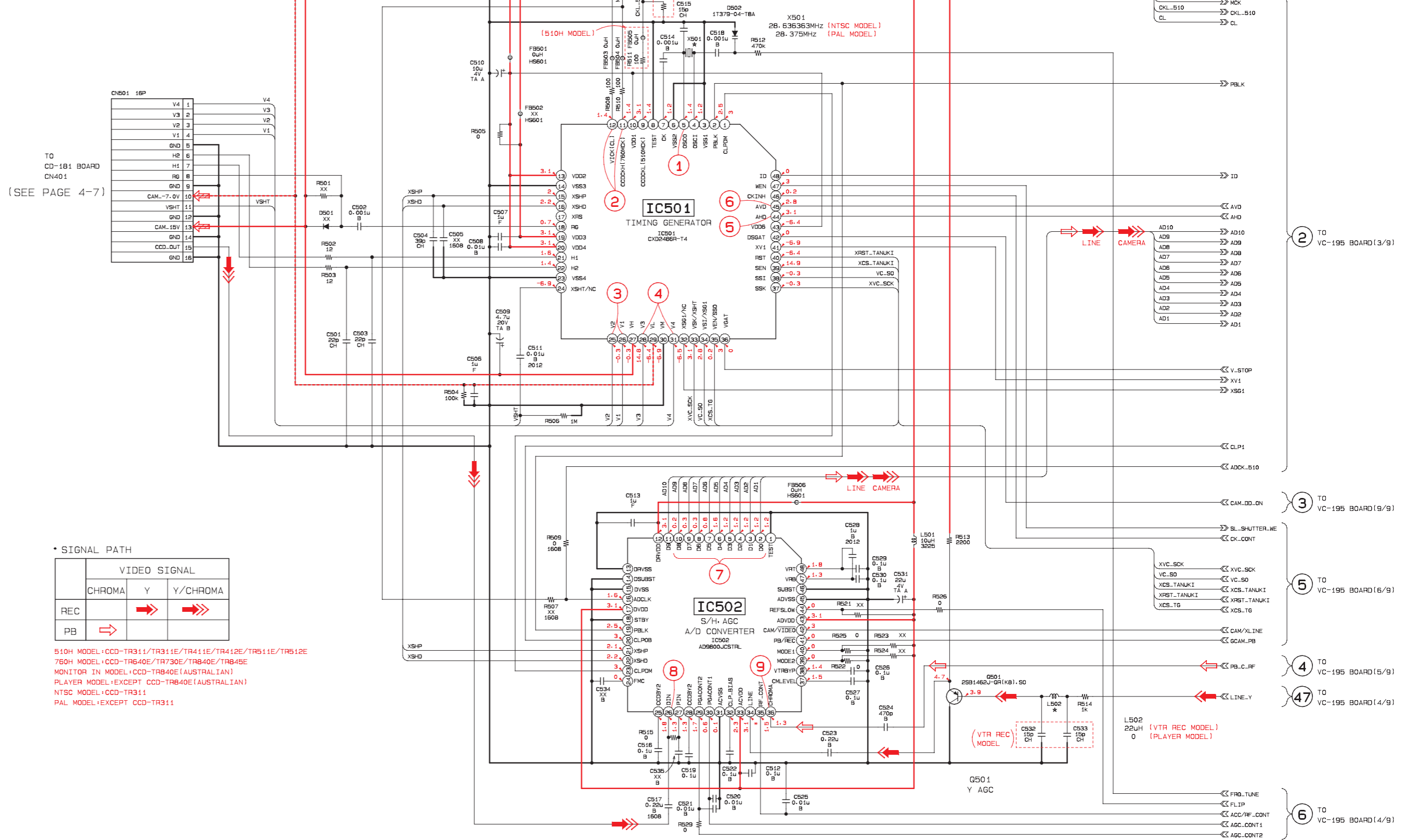

• SIGNAL PATH

	VIDEO SIGNAL		
	CHROMA	Y	Y/CHROMA
REC		→	→
PB	→		

510H MODEL: CCD-TR311/TR311E/TR411E/TR412E/TR511E/TR512E
760H MODEL: CCD-TR640E/TR730E/TR840E/TR845E
MONITOR IN MODEL: CCD-TR840E (AUSTRALIAN)
PLAYER MODEL: EXCEPT CCD-TR840E (AUSTRALIAN)
NTSC MODEL: CCD-TR311
PAL MODEL: EXCEPT CCD-TR311

- For schematic diagrams.
- Refer to page 4-13 for Printed Wiring Board.

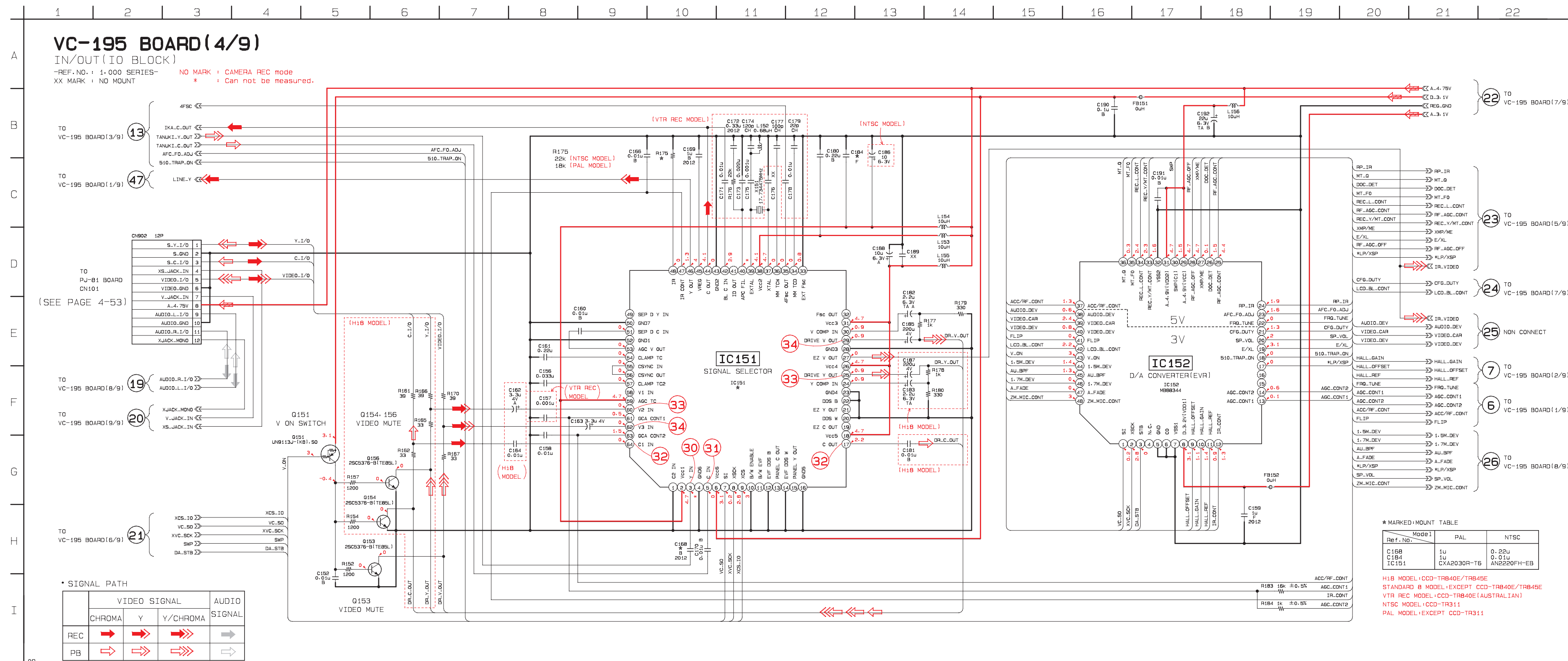

VC-195 BOARD (4/9)
CAMERA REC

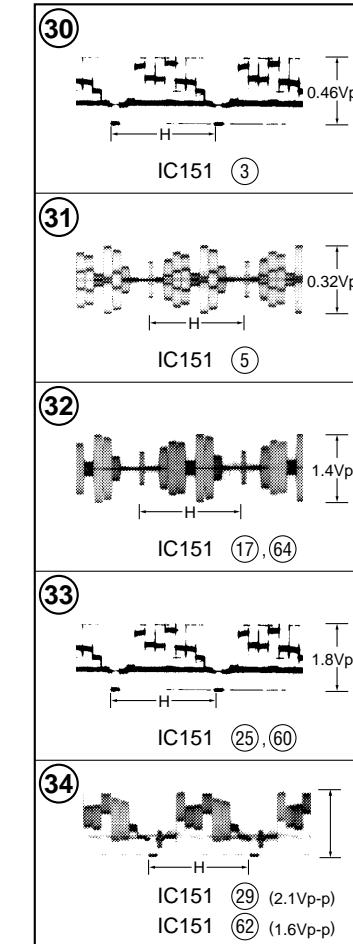

* MARKED MOUNT TABLE

Ref. No.	Model	PAL	NTSC
C168	1u		0.22u
C194	1u		0.01u
IC151	CXA2030R-T6		AVS220FH-EB

H1B MODEL+CCD-TR840E/TR845E
STANDARD B MODEL+EXCEPT CCD-TR840E/TR845E
VTR REC MODEL+CCD-TR840E(AUSTRALIAN)
NTSC MODEL+CCD-TR311
PAL MODEL+EXCEPT CCD-TR311

VC-195 BOARD(4/9)
IN/OUT (IO BLOCK)

-REF. NO. : 1-000 SERIES-
XX MARK : NO MOUNT

NO MARK : CAMERA REC mode
* : Can not be measured.

* SIGNAL PATH

	VIDEO SIGNAL			AUDIO SIGNAL
	CHROMA	Y	Y/CHROMA	
REC	→	→	→	→
PB	→	→	→	→

• For schematic diagrams.
• Refer to page 4-13 for Printed Wiring Board.

VC-195 BOARD (5/9)

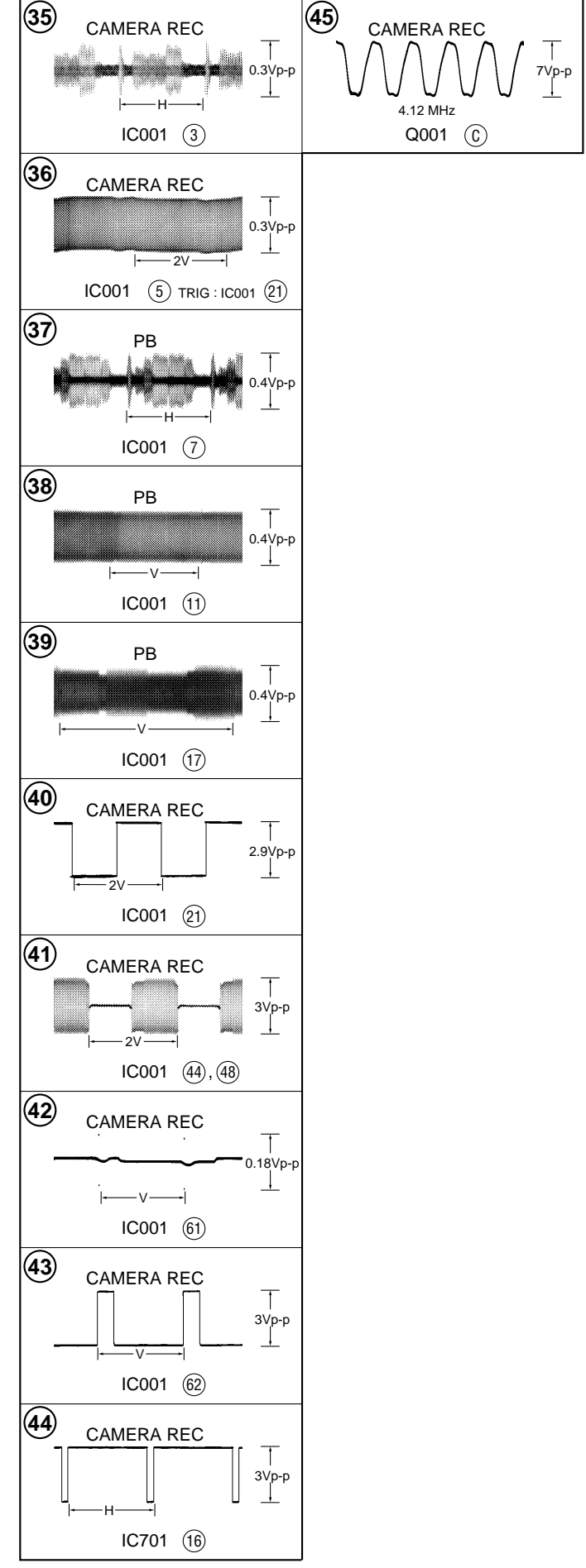

VC-195 BOARD (5/9)
REC/PB HEAD AMP (RR BLOCK)

REF. NO.: 1,000 SERIES-
XX MARK: NO MOUNT
NO MARK: CAMERA REC/PB mode
R : CAMERA REC mode
P : PB mode

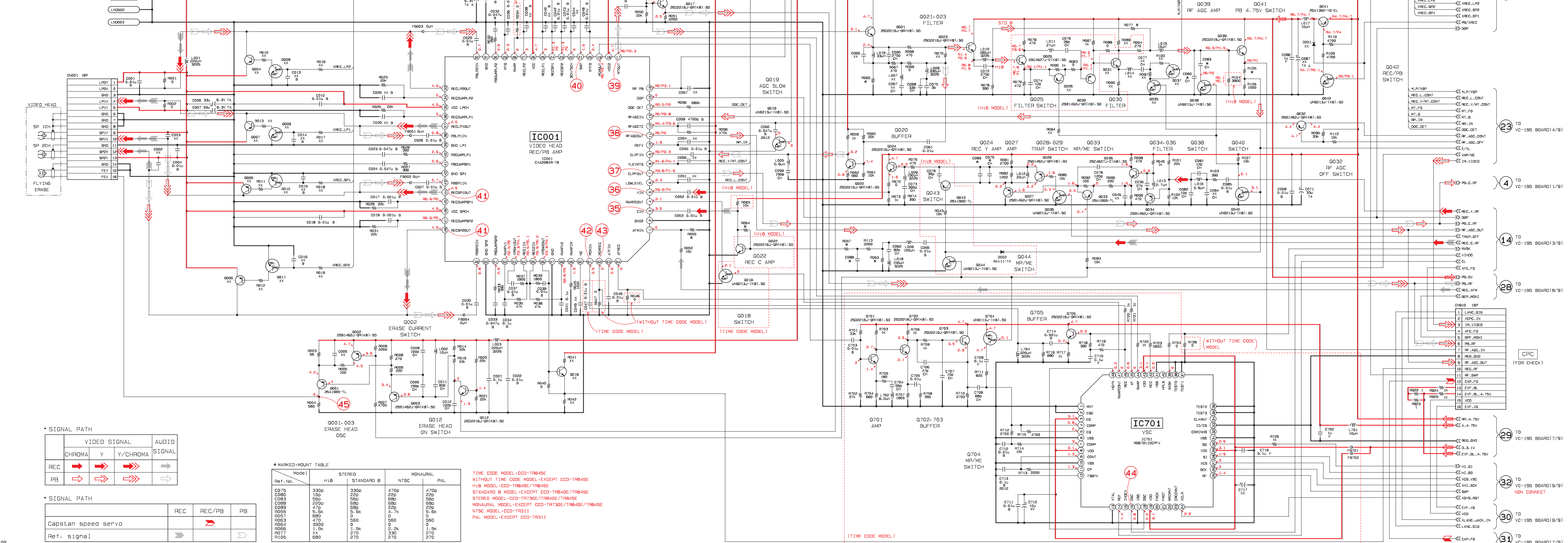

• SIGNAL PATH

	VIDEO SIGNAL			AUDIO SIGNAL
	CHROMA	Y	Y/CHROMA	
REC	→	→	→	→
PB	→	→	→	→

• SIGNAL PATH

	REC	REC/PB	PB
Capstan speed servo		→	
Ref. signal	→		→

* MARKED MOUNT TABLE

Model	STEREO		MONAURAL	
Ref. No.	H1B	STANDARD B	NTSC	PAL
C075	330p	330p	470p	470p
C080	10p	25p	25p	25p
C081	56p	56p	56p	56p
C088	47p	56p	56p	56p
C089	47p	56p	56p	56p
R057	5.1k	5.1k	0	0
R058	5.1k	5.1k	0	0
R059	47p	56p	56p	56p
R060	0	0	0	0
R061	0	0	0	0
R062	0	0	0	0
R063	47p	56p	56p	56p
R064	390p	0	0	0
R065	1.5k	1.5k	0	0
R066	XX	27p	33p	33p
R067	XX	27p	33p	33p
R105	56p	27p	27p	27p

TIME CODE MODEL: CCD-TR845E
WITHOUT TIME CODE MODEL: EXCEPT CCD-TR845E
H1B MODEL: CCD-TR840E/TR845E
STANDARD B MODEL: EXCEPT CCD-TR840E/TR845E
STEREO MODEL: EXCEPT CCD-TR730E/TR840E/TR845E
MONAURAL MODEL: EXCEPT CCD-TR730E/TR840E/TR845E
NTSC MODEL: CCD-TR311
PAL MODEL: EXCEPT CCD-TR311

- TO VC-195 BOARD(6/9)
- TO VC-195 BOARD(4/9)
- TO VC-195 BOARD(1/9)
- TO VC-195 BOARD(3/9)
- TO VC-195 BOARD(8/9)
- TO VC-195 BOARD(17/9)
- TO VC-195 BOARD(9/9)
NON CONNECT
- TO VC-195 BOARD(9/9)
- TO VC-195 BOARD(17/9)

• For schematic diagrams.
• Refer to page 4-13 for Printed Wiring Board.

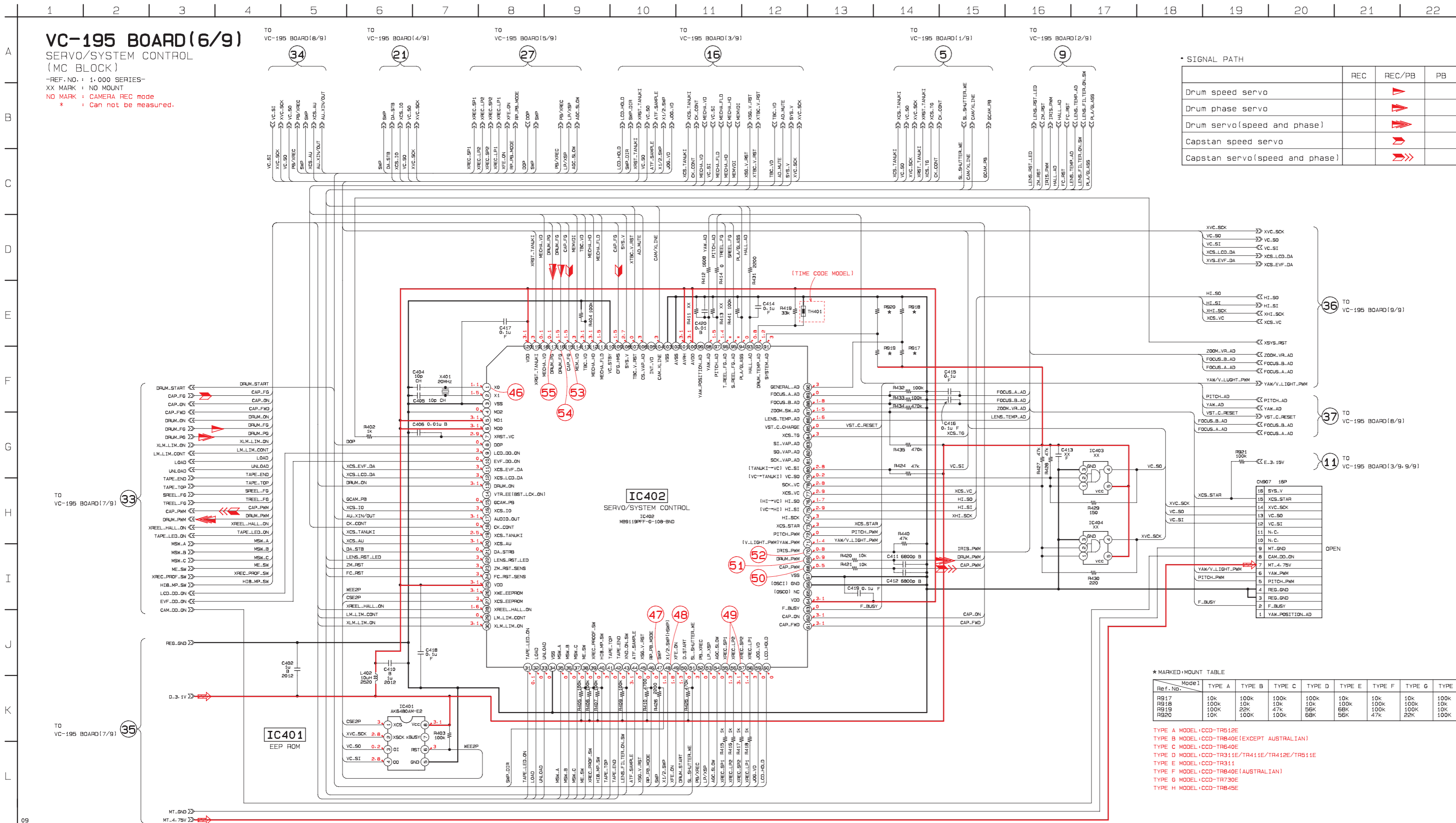

VC-195 BOARD (6/9)
CAMERA REC

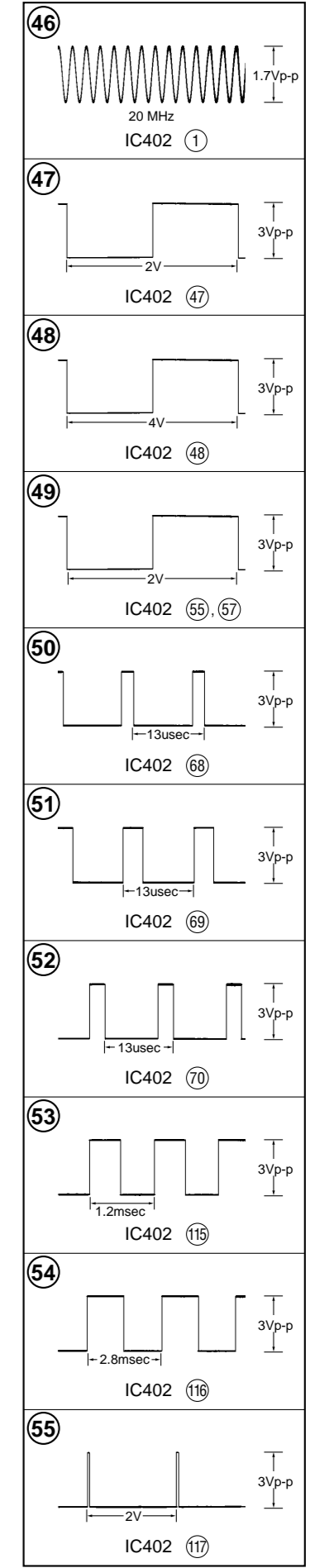

• For schematic diagrams. • Refer to page 4-13 for Printed Wiring Board.

VC-195 BOARD (7/9)

SERVO (SB BLOCK)

-REF. NO.: 1-000 SERIES-
XX MARK: NO MOUNT
NO MARK: CAMERA REC mode
*: Can not be measured.

SIGNAL PATH

	REC	REC/PB	PB
Drum speed servo		▶	
Drum phase servo		▶	
Drum servo (speed and phase)		▶▶	
Capstan phase servo		▶▶	
Capstan servo (speed and phase)		▶▶▶	

* MARKED MOUNT TABLE

Ref. No.	Mode 1	PAL	NTSC
IC452	TAB42FN-EL	LBB112V-TLM	

NTSC MODEL: CCD-TR311
PAL MODEL: EXCEPT CCD-TR311

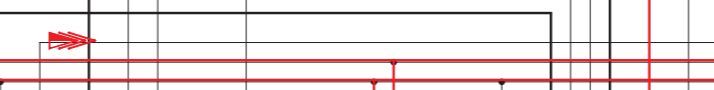
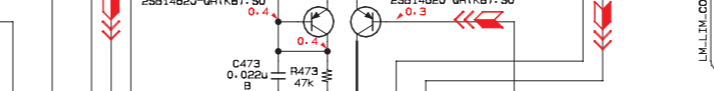
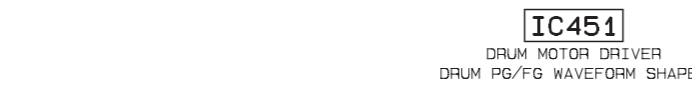
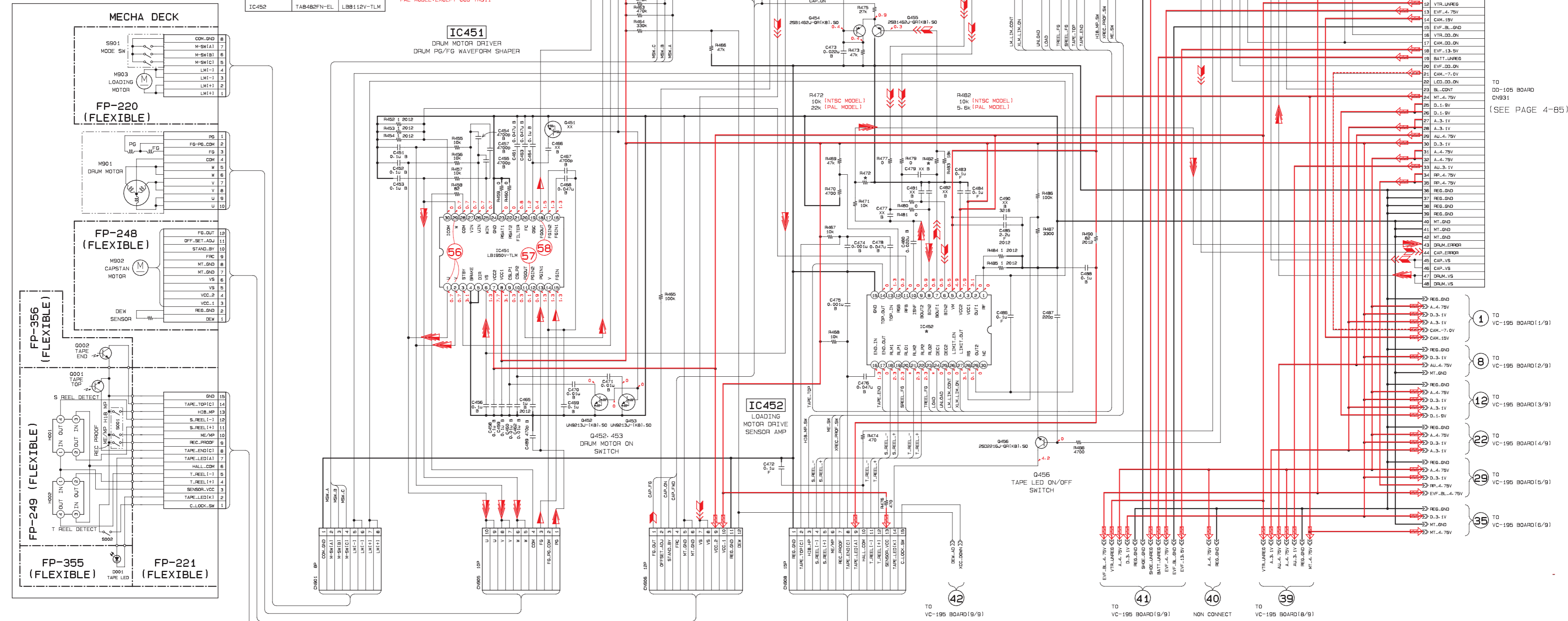

TO DD-105 BOARD
CN931
(SEE PAGE 4-85)

TO VC-195 BOARD (1/9)

TO VC-195 BOARD (2/9)

TO VC-195 BOARD (3/9)

TO VC-195 BOARD (4/9)

TO VC-195 BOARD (5/9)

TO VC-195 BOARD (6/9)

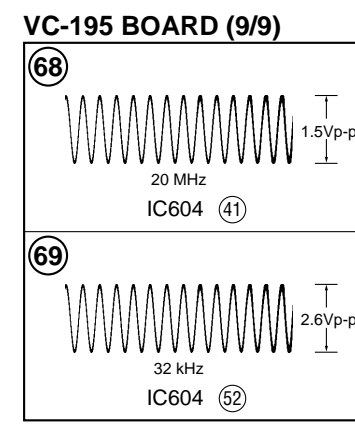

VC-195 BOARD (9/9)
MODE CONTROL (HI BLOCK)

-REF. NO.: 1,000 SERIES-
XX MARK: NO MOUNT
NO MARK: CAMERA REC mode

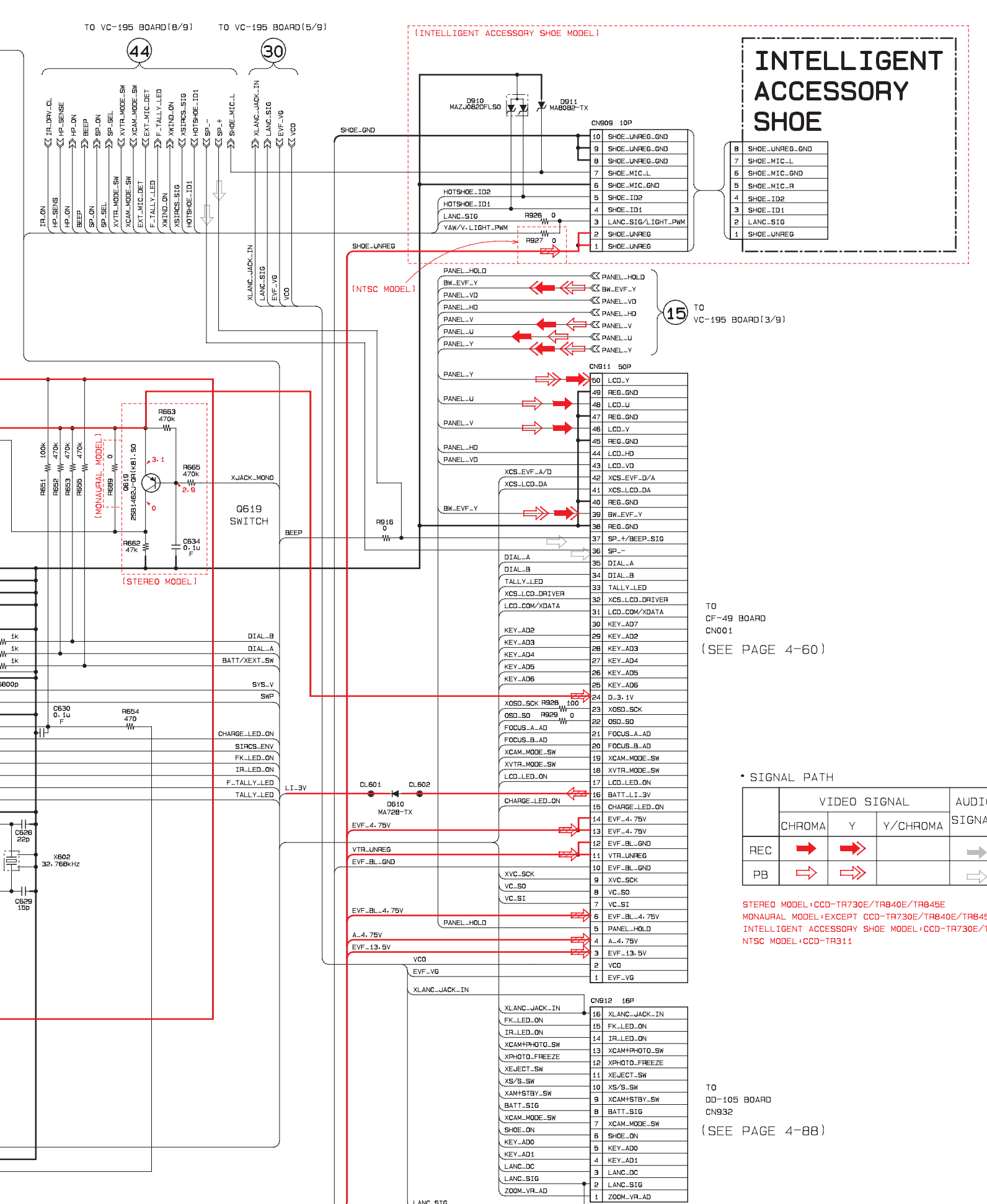
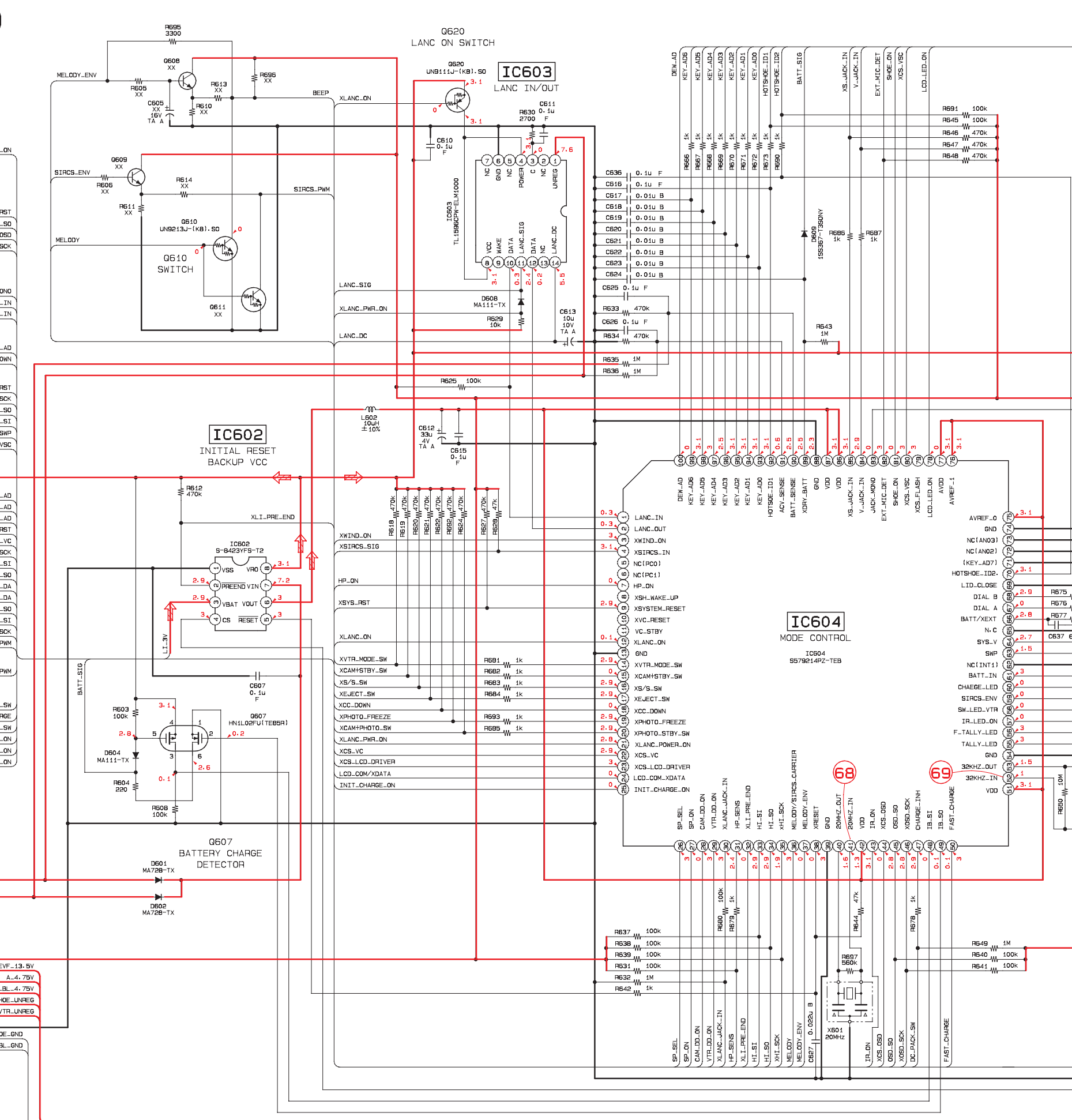
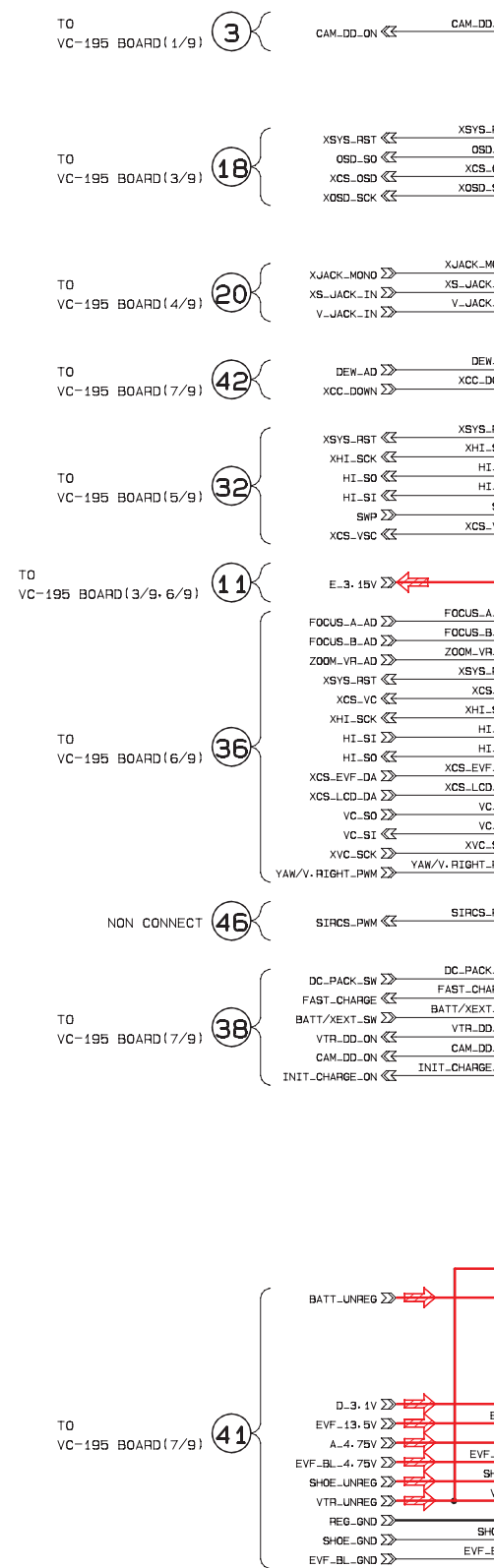

SIGNAL PATH

	VIDEO SIGNAL			AUDIO SIGNAL
	CHROMA	Y	Y/CHROMA	
REC	→	→	→	→
PB	→	→	→	→

STEREO MODEL: CCD-TR730E/TR840E/TR845E
MONAURAL MODEL: EXCEPT CCD-TR730E/TR840E/TR845E
INTELLIGENT ACCESSORY SHOE MODEL: CCD-TR730E/TR840E/TR845E
NTSC MODEL: CCD-TR311

PJ-81 (AV IN/OUT) PRINTED WIRING BOARD
- Ref No. PJ-81 BOARD: 3,000 series -

PJ-81 BOARD (SIDE B)

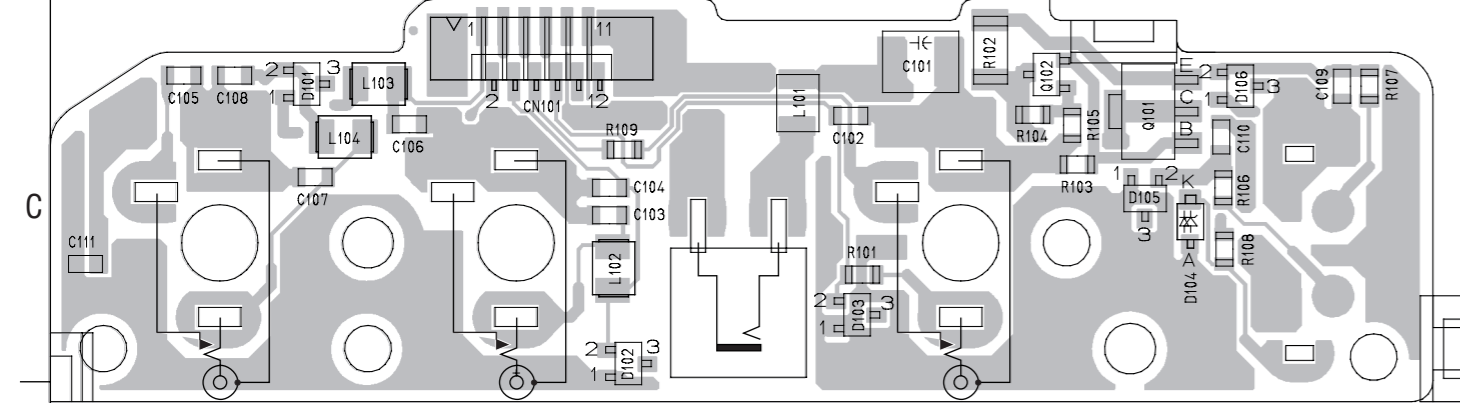

PJ-81 BOARD (SIDE A)

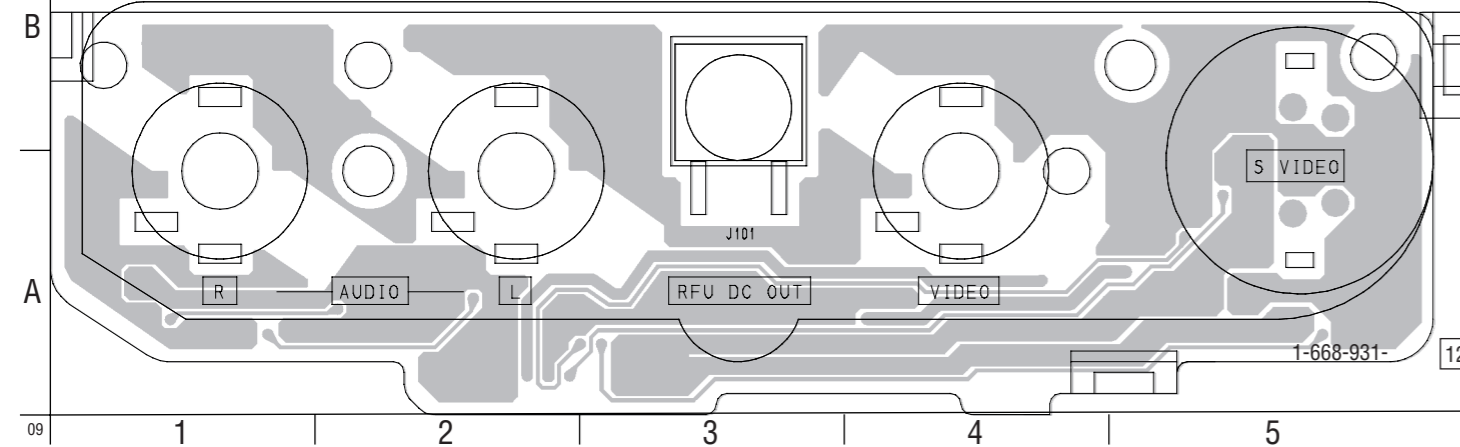

PJ-81 BOARD

C101	C-4
C102	C-3
C103	C-3
C104	C-3
C105	C-3
C106	C-2
C107	C-1
C108	C-1
C109	C-5
C110	C-5
C111	C-1
CN101	C-2
D101	C-1
D102	C-3
D103	C-4
D106	C-5
D107	C-5
J101	A-3
L101	C-3
L102	C-3
L103	C-2
L104	C-2
Q101	C-5
Q102	C-4
R101	C-4
R102	C-4
R103	C-4
R104	C-4
R105	C-4
R106	C-5
R107	C-5
R108	C-5
R109	C-3

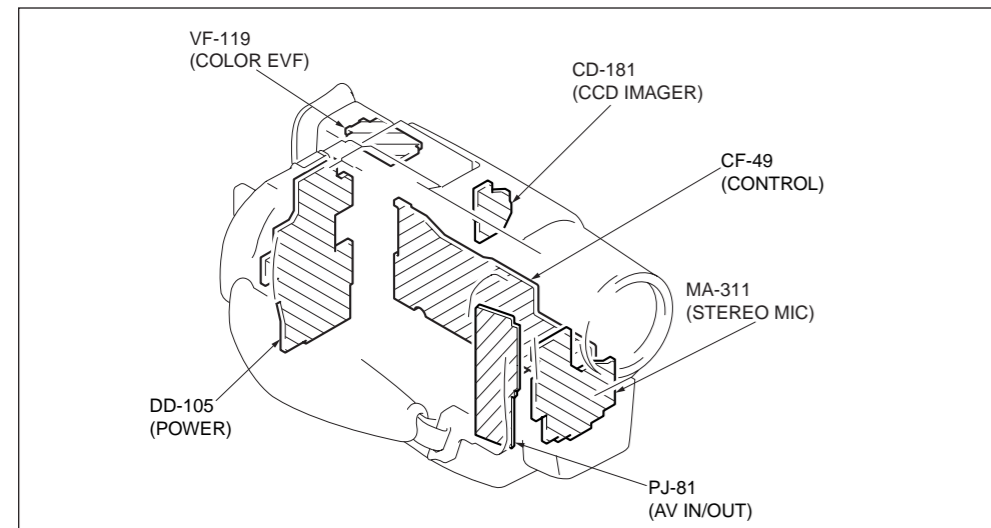
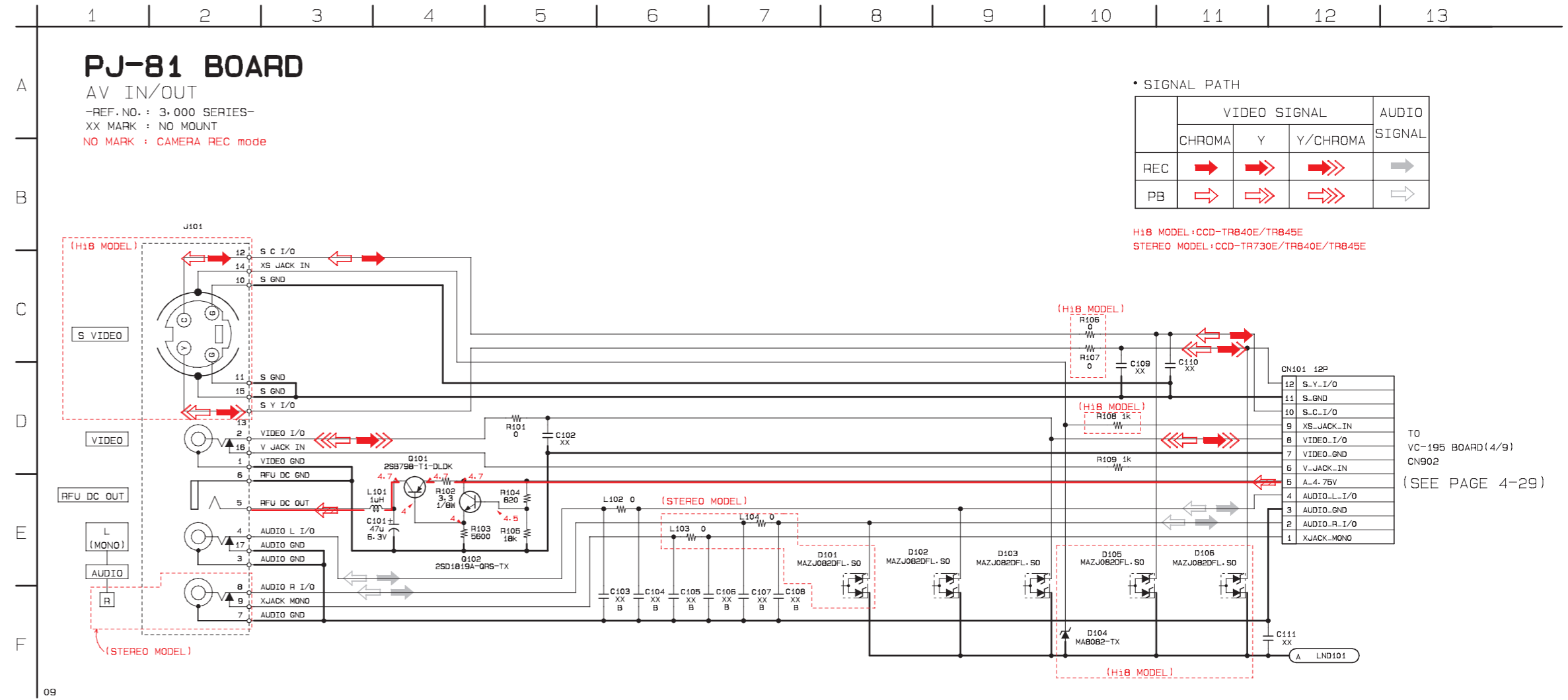

• For Printed Wiring Boards.

There are few cases that the part isn't mounted in this model is printed on this diagram.

• Chip diode

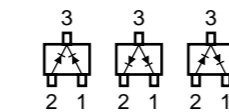

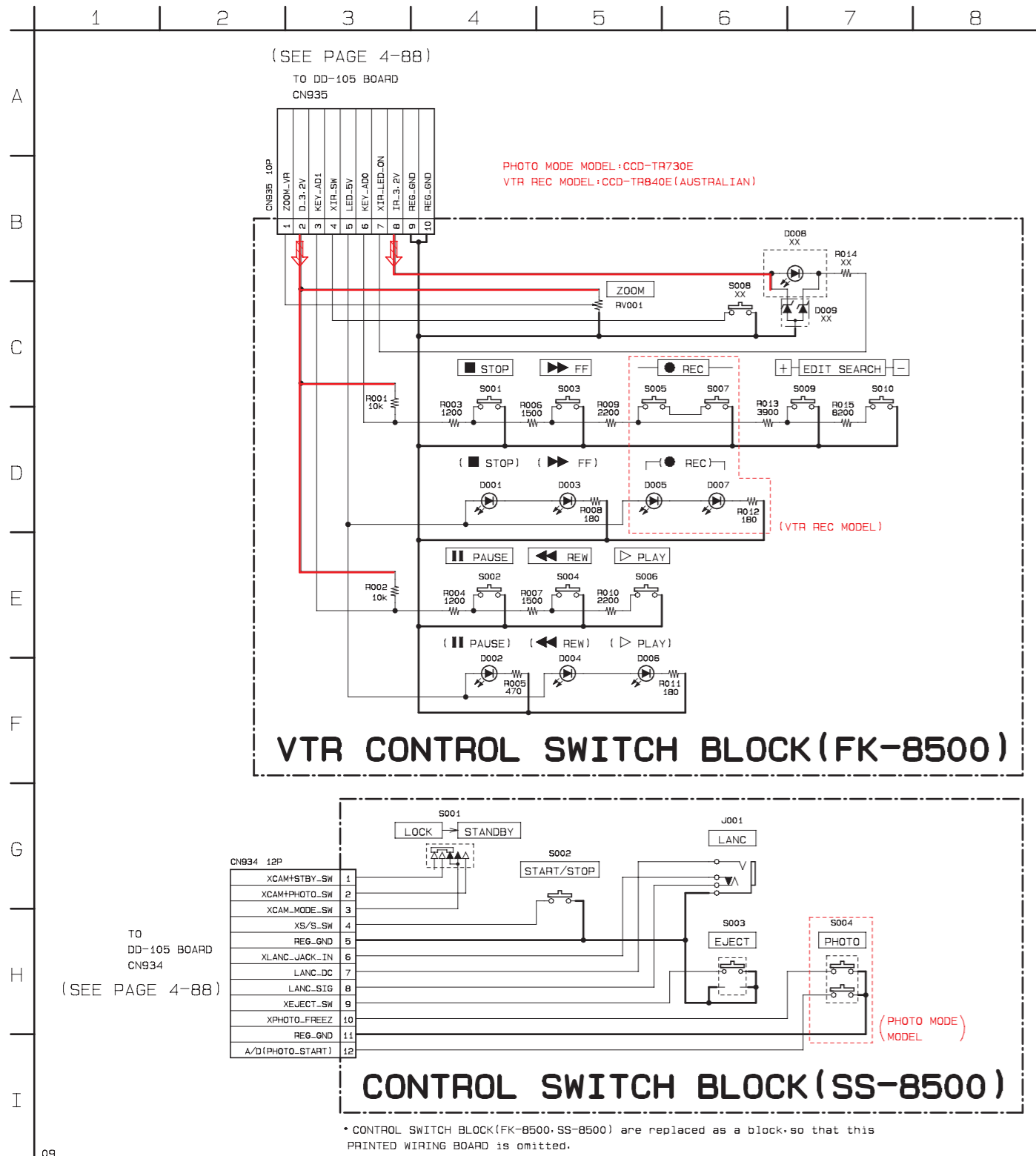

MA-311 BOARD
STEREO MIC, NIGHT SHOT
-REF. NO. : 3-000 SERIES-
NO MARK : CAMERA REC mode

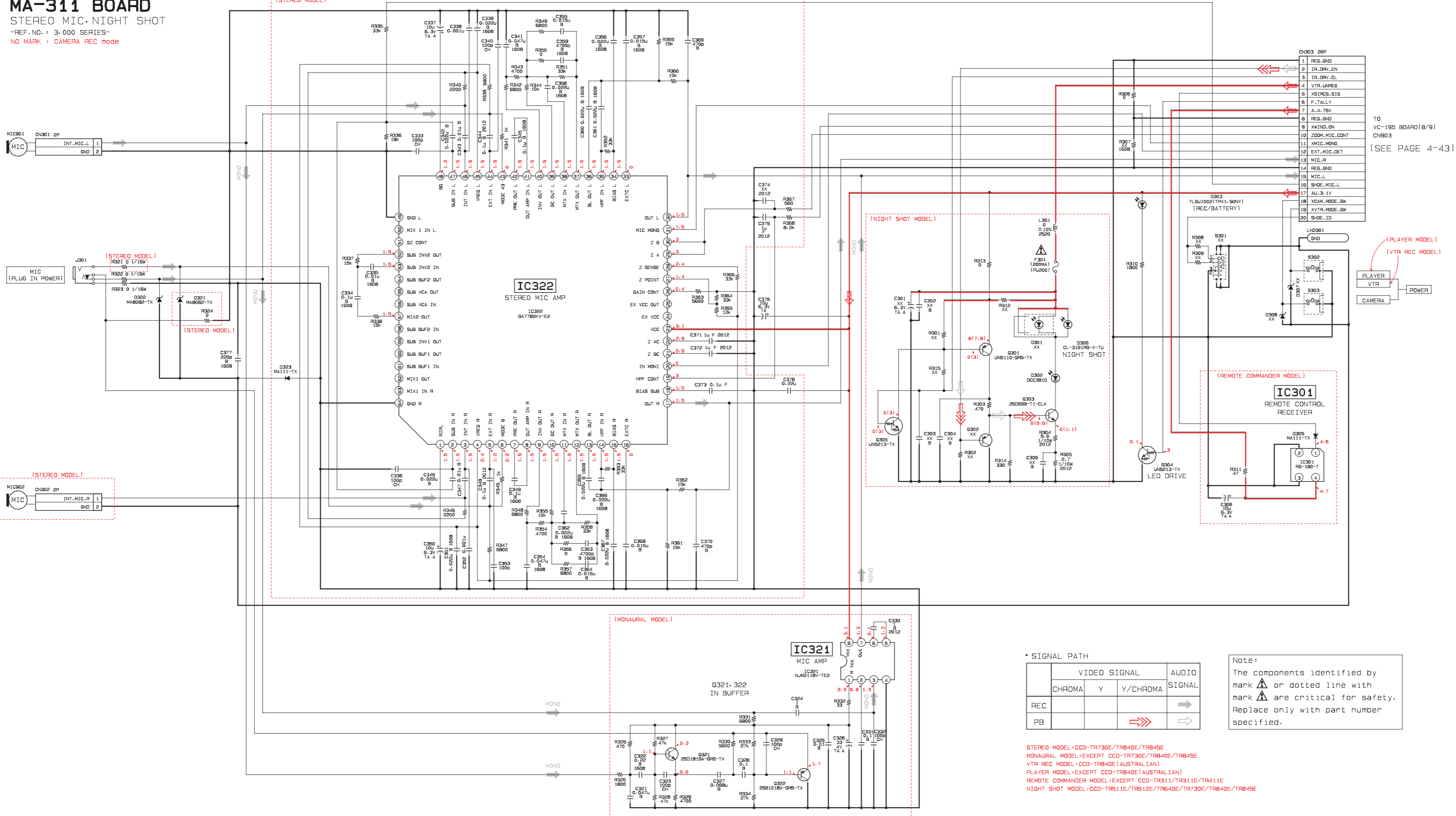

TO VC-195 BOARD(8/9)
CN903 (SEE PAGE 4-43)

(PLAYER MODEL)
(VTR REC MODEL)

• SIGNAL PATH

	VIDEO SIGNAL		AUDIO SIGNAL
	CHROMA	Y / CHROMA	
REC			→
PB		⇒	⇨

Note:
The components identified by mark or dotted line with mark are critical for safety. Replace only with part number specified.

STEREO MODEL : CCD-TR730E/TR840E/TR845E
MONAURAL MODEL : EXCEPT CCD-TR730E/TR840E/TR845E
VTR REC MODEL : EXCEPT CCD-TR840E(AUSTRALIAN)
PLAYER MODEL : EXCEPT CCD-TR840E(AUSTRALIAN)
REMOTE COMMANDER MODEL : EXCEPT CCD-TR311/TR311E/TR411E
NIGHT SHOT MODEL : CCD-TR511E/TR512E/TR640E/TR730E/TR840E/TR845E

1 2 3 4 5 6 7 8 9 10 11 12 13 14 15 16 17 18 19 20 21 22 23

A
B
C
D
E
F
G
H
I
J
K
L

CF-49 BOARD

CONTROL
-REF. NO. : 3-000 SERIES-
XX MARK : NO MOUNT
NO MARK : CAMERA REC mode

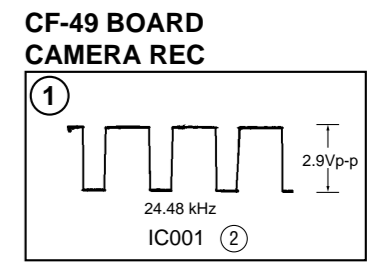
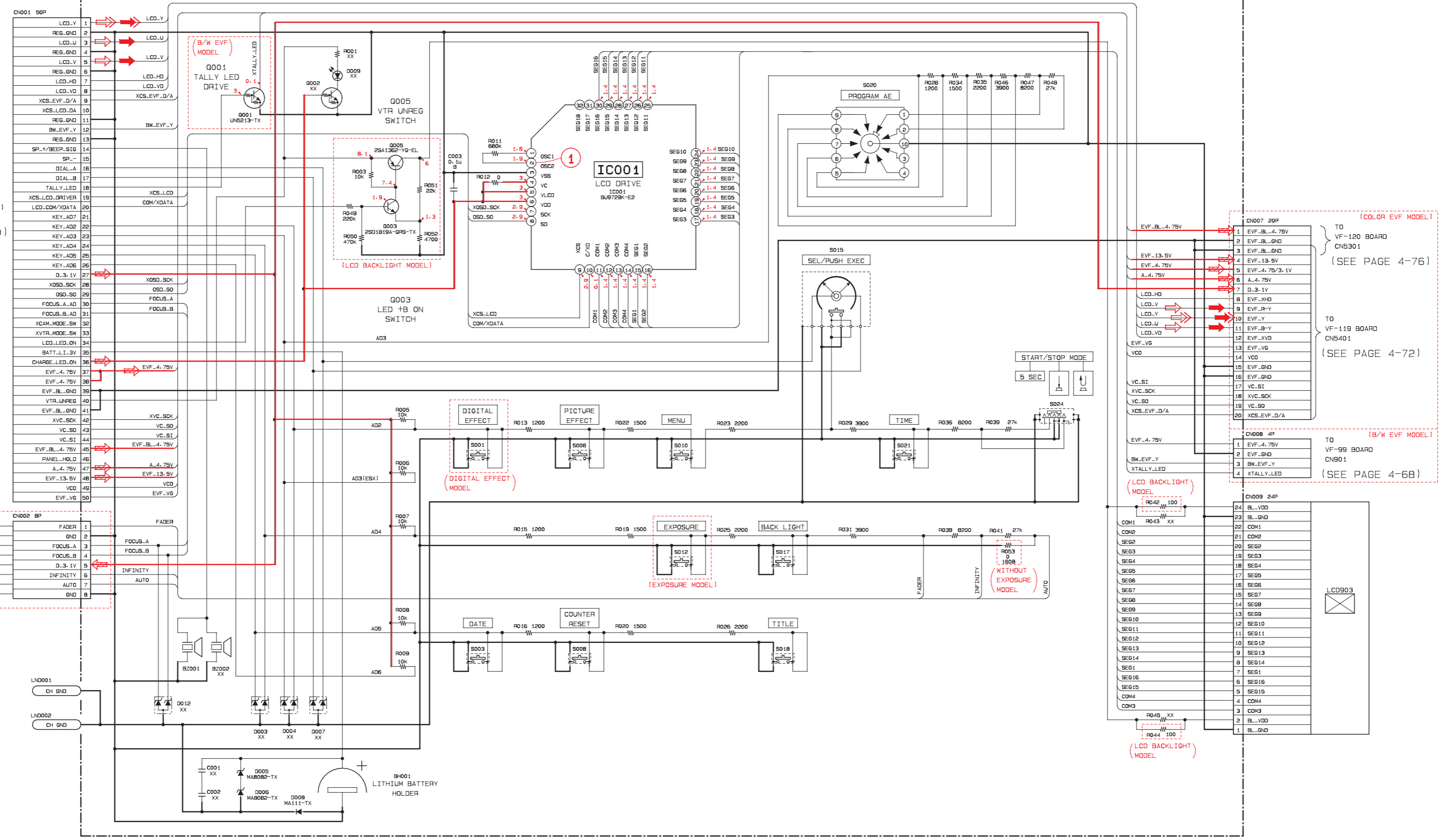

* SIGNAL PATH

	VIDEO SIGNAL		
	CHROMA	Y	Y/CHROMA
REC	→	→	
PB	→	→	

TO VC-195 BOARD(9/9) CN911 (SEE PAGE 4-50)

LCD BACKLIGHT MODEL : CCD-TR511E/TR512E/TR640E/TR730E/TR840E/TR845E
EXPOSURE MODEL : EXCEPT CCD-TR311/TR311E/TR411E/TR412E
WITHOUT EXPOSURE MODEL : CCD-TR311/TR311E/TR411E/TR412E
MANUAL FOCUS MODEL : CCD-TR511E/TR512E/TR640E/TR730E/TR840E/TR845E
COLOR EVF MODEL : CCD-TR512E/TR730E
B/W EVF MODEL : EXCEPT CCD-TR512E/TR730E
DIGITAL EFFECT MODEL : CCD-TR730E

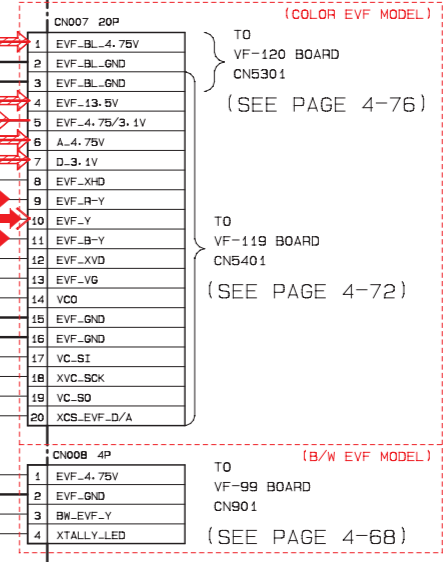
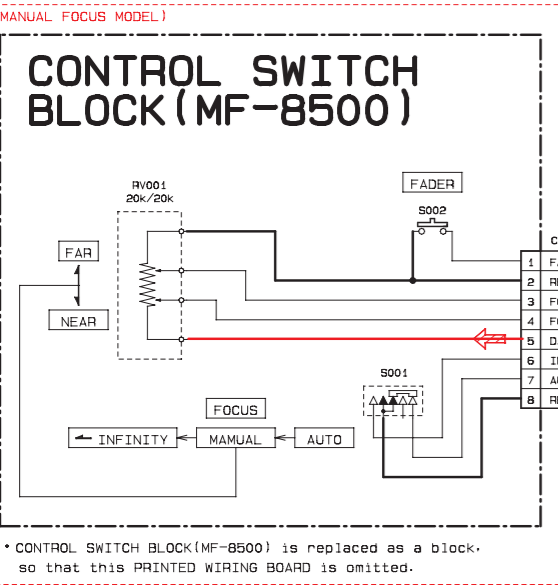

CF-49 (CONTROL) PRINTED WIRING BOARD
- Ref No. CF-49 BOARD: 3,000 series -

CF-49 BOARD

BH001	B-18	R016	C-4
BZ001	B-15	R019	B-11
BZ002	B-15	R020	C-4
		R022	B-8
		R023	A-8
C001	B-2	R025	B-1
C002	B-2	R026	C-4
C003	B-12	R028	A-6
		R029	A-14
CN002	A-14	R031	B-2
CN007	C-14	R034	A-6
CN008	D-14	R035	B-6
CN009	D-6	R038	B-2
		R039	A-14
D003	B-3	R041	B-2
D004	C-11	R042	D-14
D005	B-2	R043	C-14
D006	B-2	R044	C-11
D007	A-8	R045	C-11
D008	B-2	R046	B-6
D009	D-10	R047	B-8
D012	B-5	R048	B-8
		R049	C-11
IC001	B-12	R050	C-11
		R051	B-12
Q001	C-15	R052	C-11
Q002	D-10	R053	B-1
Q003	B-12	S001	C-10
Q005	B-12	S003	B-3
		S006	B-9
R001	D-10	S008	D-4
R003	B-12	S010	A-9
R005	C-11	S012	C-10
R006	C-11	S015	A-10
R007	B-11	S017	B-1
R008	B-3	S018	B-6
R009	C-11	S020	B-7
R011	B-12	S021	B-4
R012	B-13	S024	A-5
R013	C-11		
R015	B-11		

CF-49 BOARD (SIDE B)

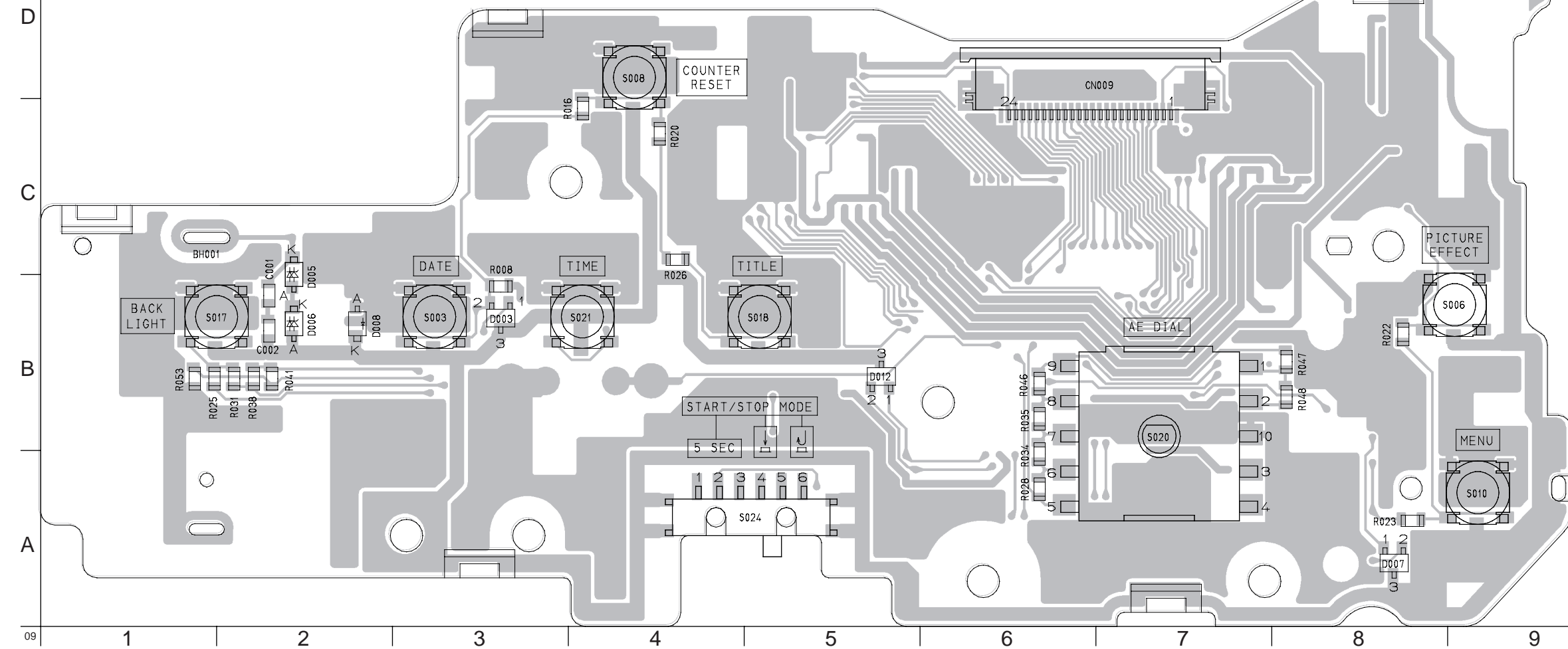

CF-49 BOARD (SIDE A)

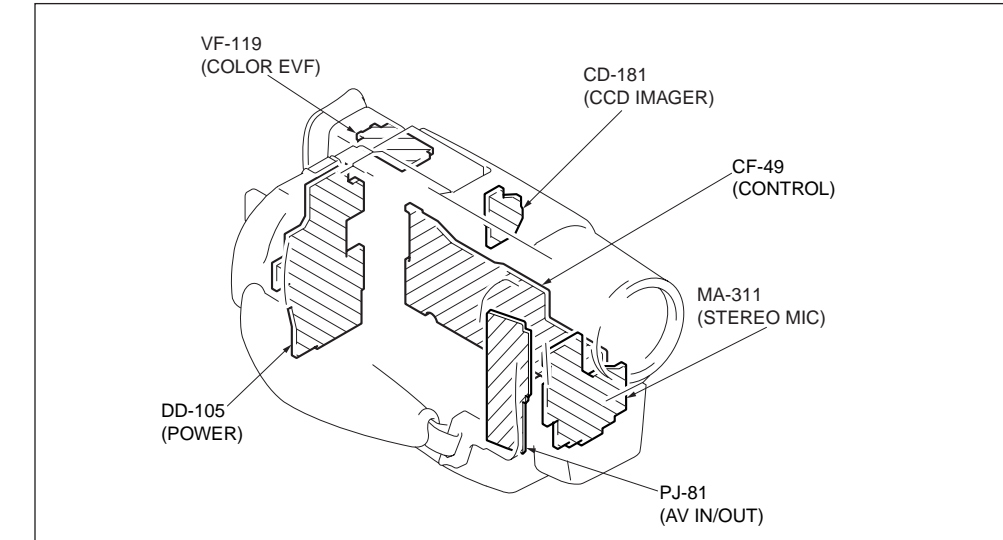
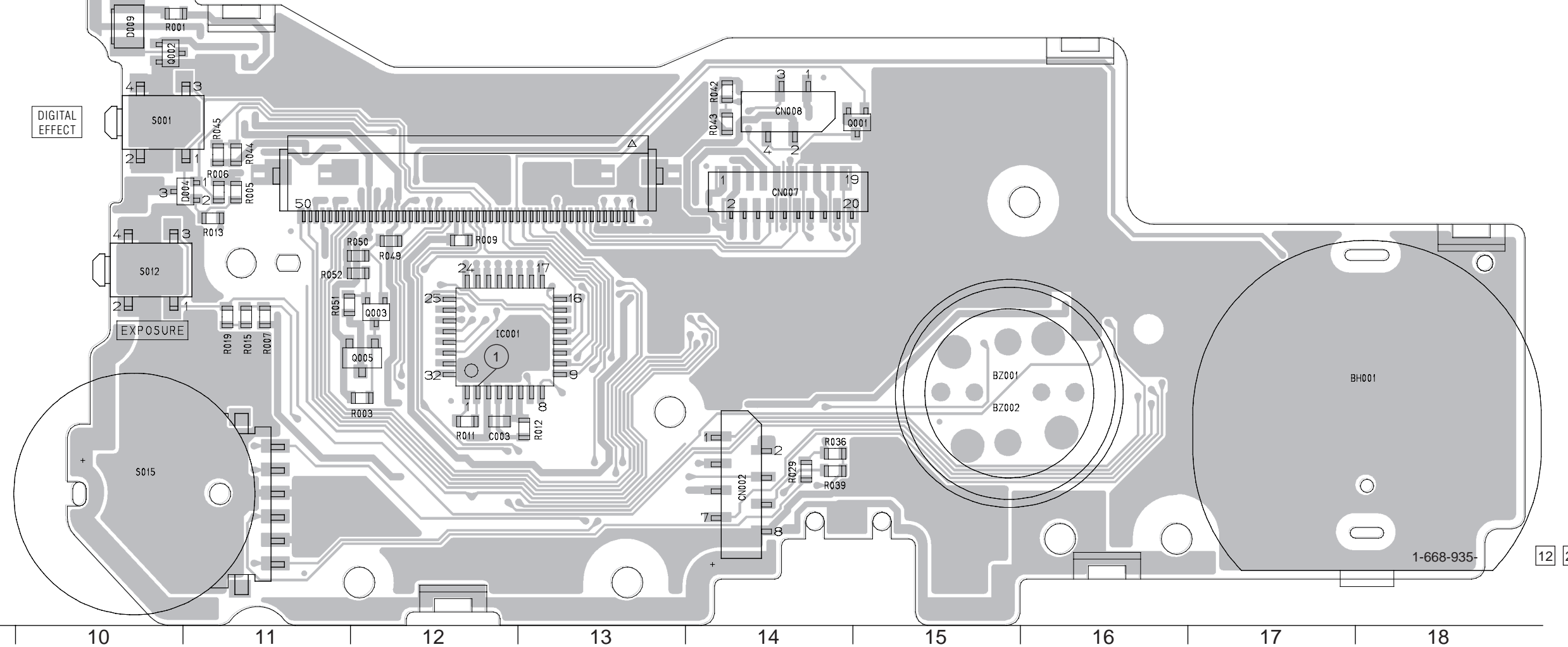

• For Printed Wiring Boards.
There are few cases that the part isn't mounted in this model is printed on this diagram.

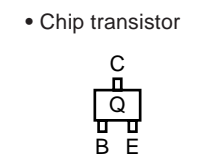

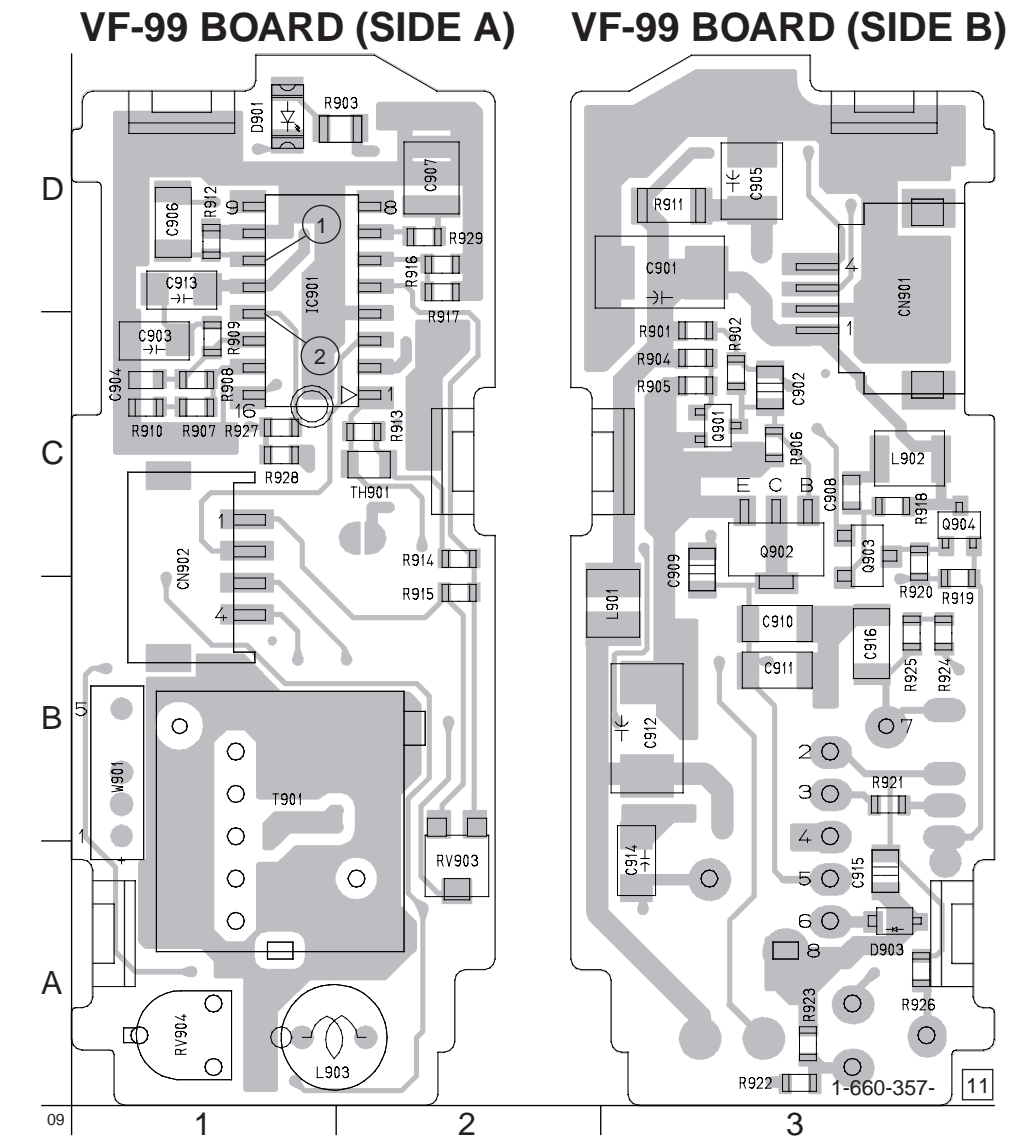
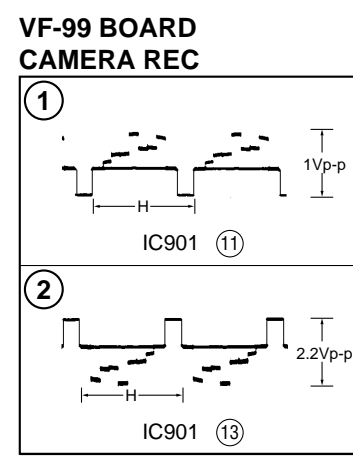
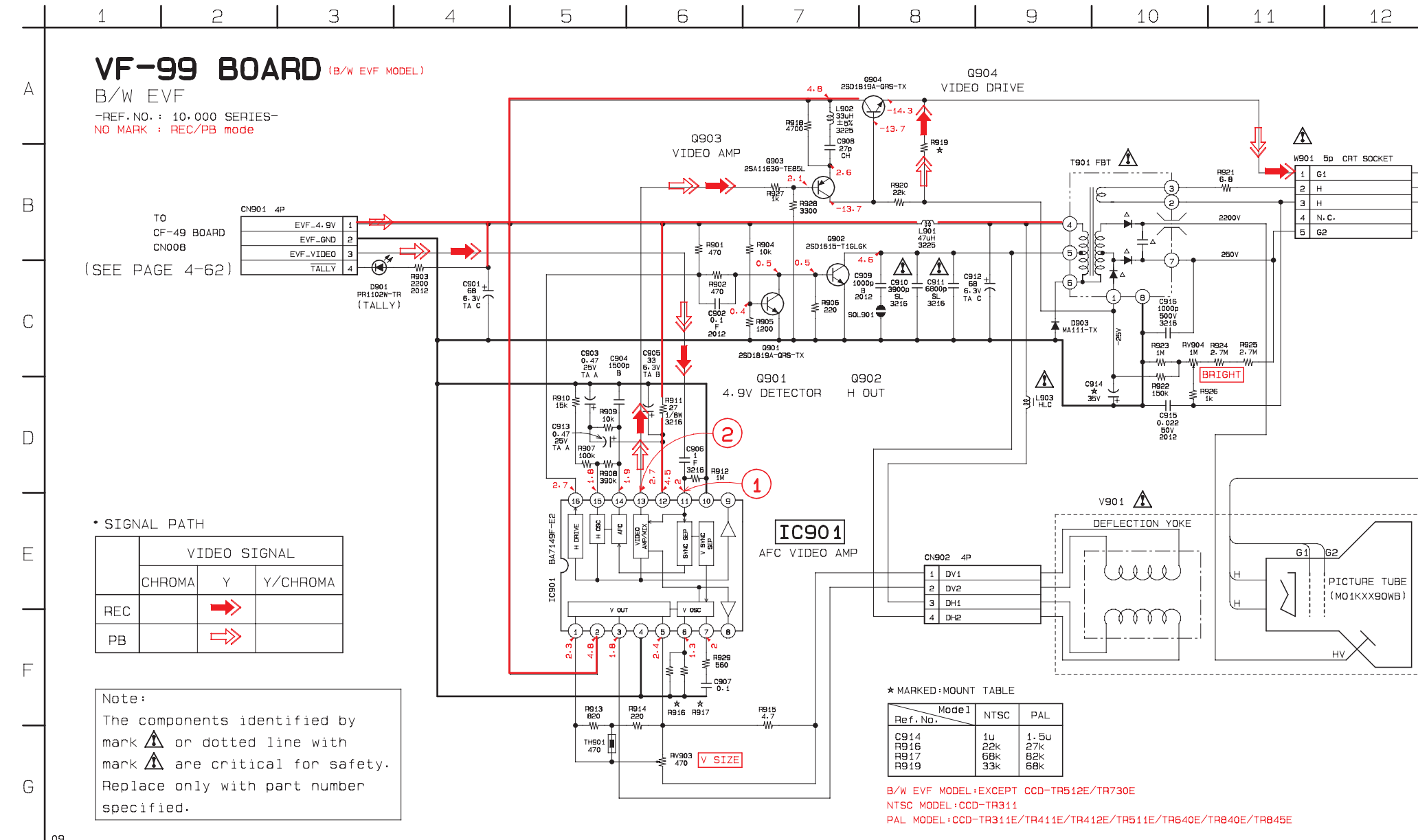

VF-99 BOARD

C901	D-3	R919	B-3
C902	C-3	R920	C-3
C903	C-1	R921	B-3
C904	C-1	R922	A-3
C905	D-3	R923	A-3
C906	D-1	R924	B-3
C907	D-2	R925	B-3
C908	C-3	R926	A-3
C909	C-3	R927	C-1
C910	B-3	R928	C-1
C911	B-3	R929	D-2
C912	B-3		
C913	D-1	RV903	A-2
C914	A-3	RV904	A-1
C915	A-3		
C916	B-3	T901	B-1
CN901	D-3	TH901	C-2
CN902	C-1	W901	B-1
D901	D-1		
D903	A-3		
IC901	D-1		
L901	B-3		
L902	C-3		
L903	A-1		
Q901	C-3		
Q902	C-3		
Q903	C-3		
Q904	C-3		
R901	C-3		
R902	C-3		
R903	D-2		
R904	C-3		
R905	C-3		
R906	C-3		
R907	C-1		
R908	C-1		
R909	C-1		
R910	C-1		
R911	D-3		
R912	D-1		
R913	C-2		
R914	C-2		
R915	B-2		
R916	D-2		
R917	D-2		
R918	C-3		

- For Printed Wiring Boards.
- This board is four-layer print board. However, the patterns of layers 2 to 3 have not been included in the diagram.

There are few cases that the part isn't mounted in this model is printed on this diagram.

- Chip transistor
-

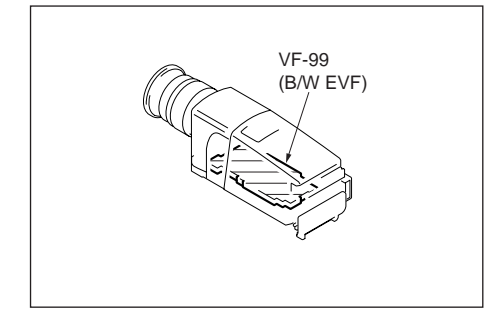

VF-119 (COLOR EVF (COLOR EVF MODEL)) PRINTED WIRING BOARD
- Ref No. VF-119 BOARD: 10,000 series -

VF-119 BOARD (SIDE B)

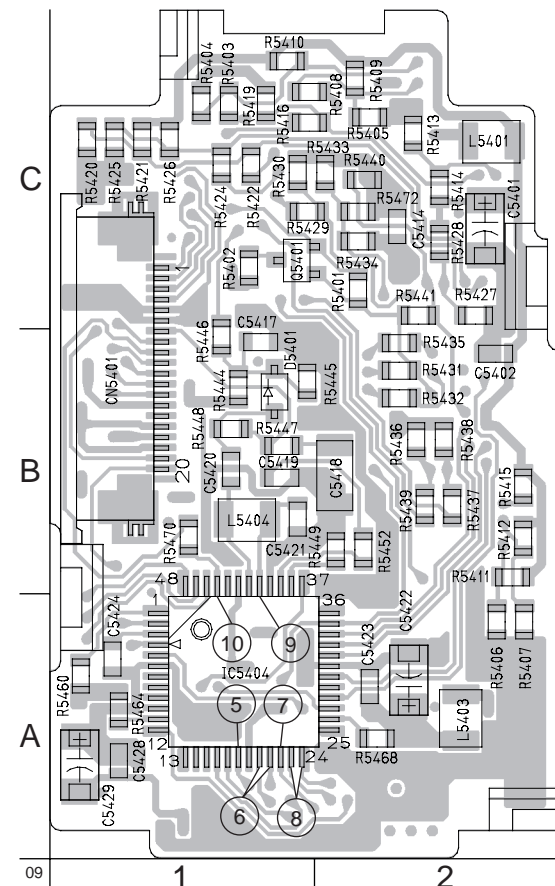

VF-119 BOARD (SIDE A)

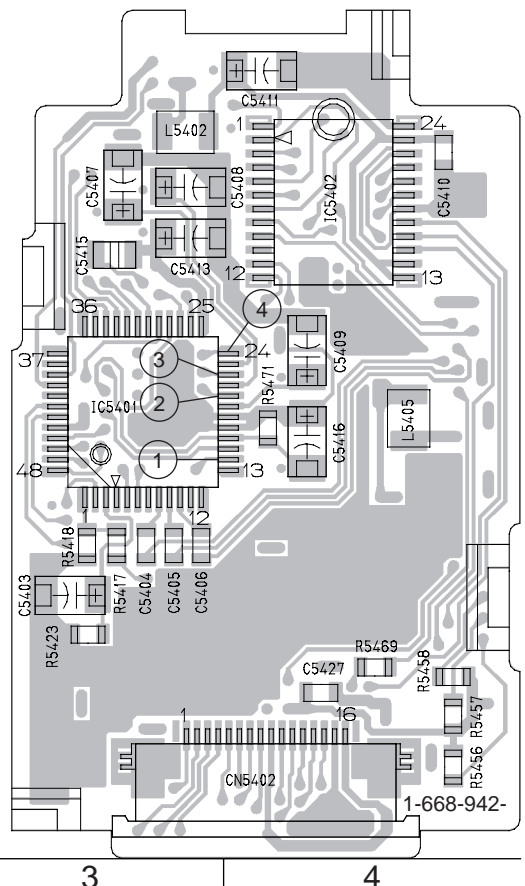

- For Printed Wiring Boards.
- This board is four-layer print board. However, the patterns of layers 2 to 3 have not been included in the diagram.

There are few cases that the part isn't mounted in this model is printed on this diagram.

- Chip transistor

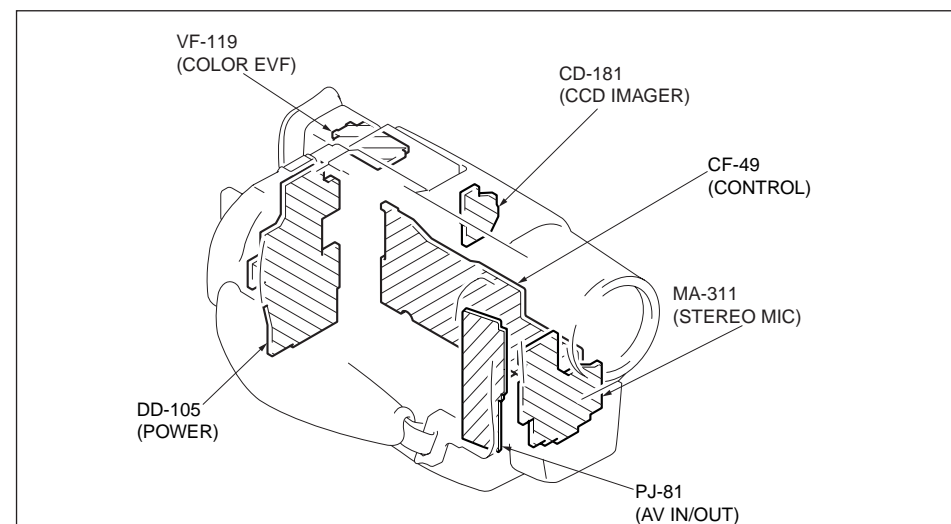
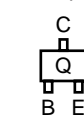

VF-119 BOARD

C5401	C-2	R5410	C-1
C5402	B-2	R5411	B-2
C5403	A-3	R5412	B-2
C5404	B-3	R5414	C-2
C5405	B-3	R5415	B-2
C5406	B-3	R5416	B-2
C5407	C-3	R5417	B-3
C5408	C-3	R5418	B-3
C5409	B-4	R5418	C-2
C5410	C-4	R5418	C-1
C5411	C-4	R5419	C-1
C5413	C-3	R5420	C-1
C5415	C-3	R5421	C-1
C5416	B-4	R5422	C-1
C5417	B-1	R5422	A-3
C5418	B-2	R5424	C-1
C5419	B-1	R5425	C-1
C5420	B-1	R5426	C-1
C5421	B-1	R5427	C-2
C5422	A-2	R5428	C-2
C5423	A-2	R5429	C-1
C5424	A-1	R5430	C-2
C5427	A-4	R5431	B-2
C5428	A-1	R5432	B-2
C5429	A-1	R5433	C-2
C5434	C-2	R5434	C-2
C5435	B-2	R5435	B-2
C5436	B-2	R5436	B-2
C5437	B-2	R5437	B-2
D5401	B-1	R5438	B-2
IC5401	B-3	R5439	B-2
IC5402	C-4	R5440	C-2
IC5404	A-1	R5441	C-2
L5401	C-2	R5444	B-1
L5402	C-3	R5445	B-1
L5403	A-2	R5446	B-1
L5404	B-1	R5448	B-2
L5405	B-4	R5449	B-2
		R5452	B-2
		R5456	A-4
		R5457	A-4
		R5458	A-4
		R5460	A-1
		R5464	A-1
		R5468	A-4
		R5469	A-4
		R5470	B-1
		R5471	B-4
		R5472	B-4
		R5472	C-2
		R5472	C-2

VF-119 BOARD
CAMERA REC

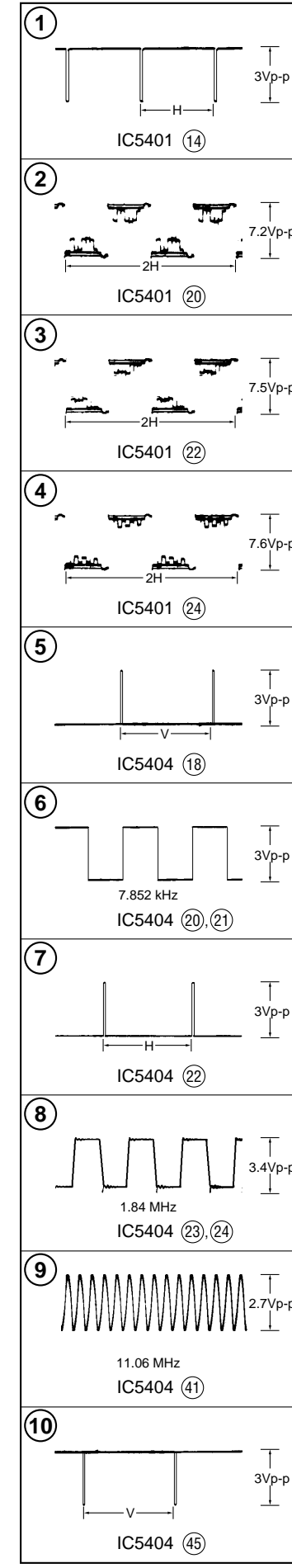

VF-119 BOARD
COLOR EVF

(COLOR EVF MODEL)
-REF. NO. : 10,000 SERIES-
XX MARK : NO MOUNT
NO MARK : CAMERA REC mode

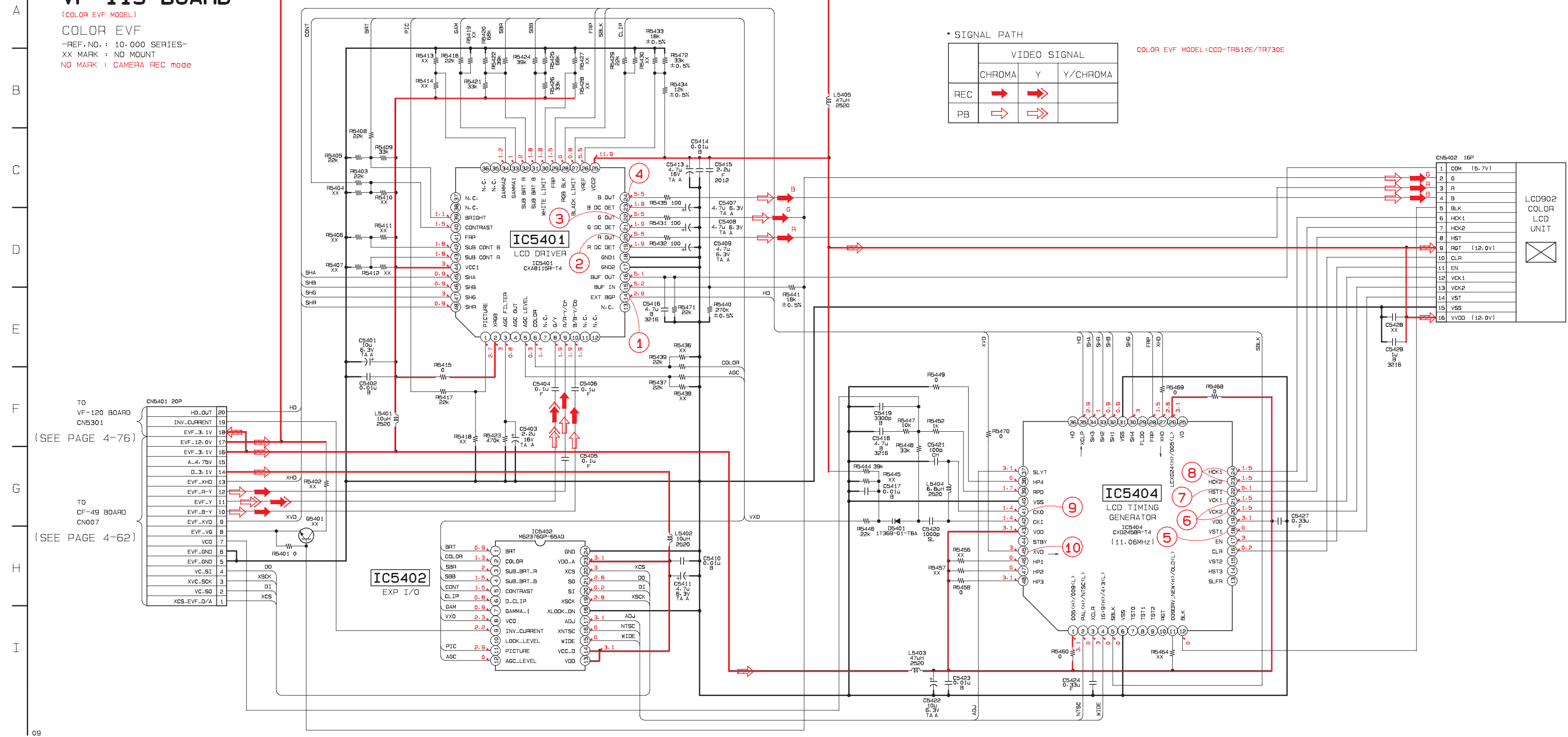

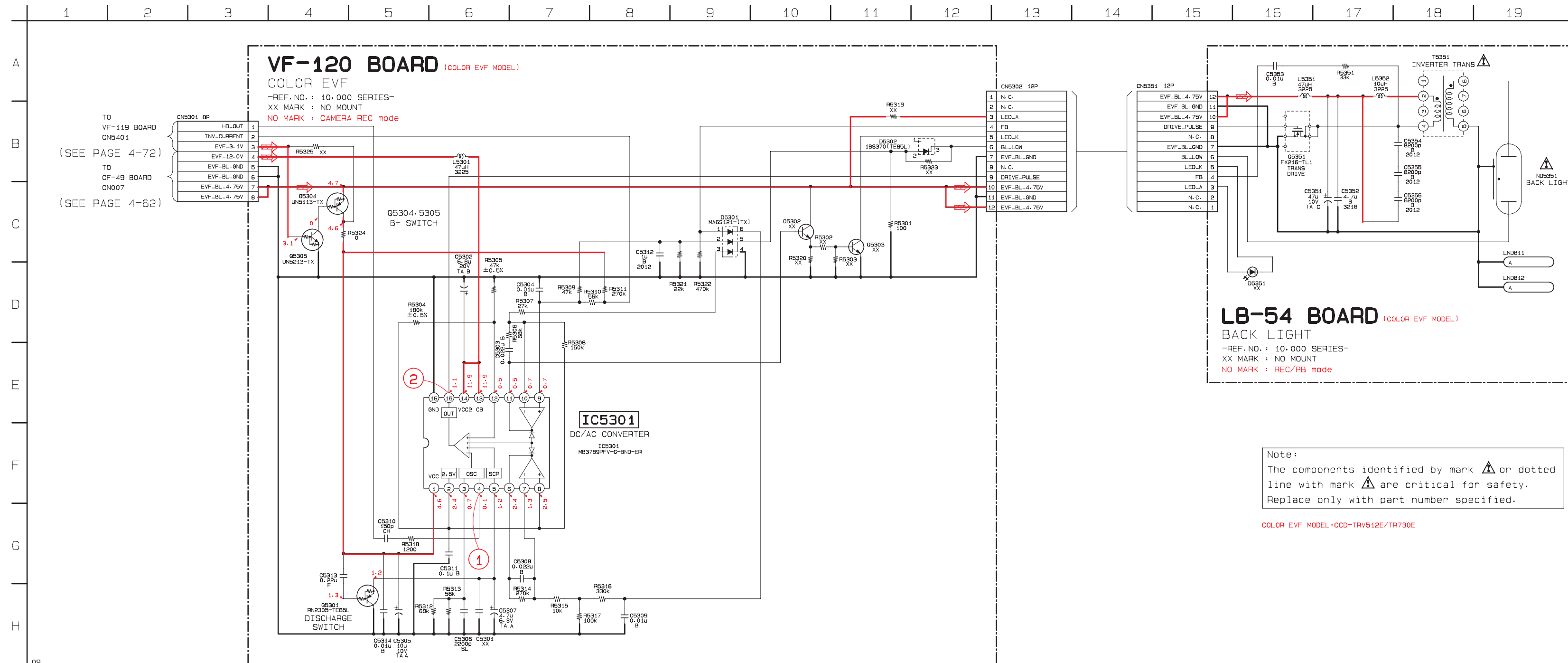

Note:
The components identified by mark Δ or dotted line with mark Δ are critical for safety.
Replace only with part number specified.

COLOR EVF MODEL : CCD-TRV512E/TR730E

CCD-TR311/TR311E/TR411E/TR412E/TR511E/TR512E/
TR640E/TR730E/TR840E/TR845E

VF-120 (COLOR EVF), LB-54 (BACK LIGHT) (COLOR EVF MODEL) PRINTED WIRING BOARDS
- Ref No. VF-120 BOARD: 10,000 series, LB-54 BOARD: 10,000 series -

VF-120 BOARD

C5301	B-3	R5304	A-3
C5302	A-4	R5305	A-4
C5303	A-4	R5306	A-4
C5304	A-3	R5307	A-3
C5305	A-4	R5309	A-3
C5306	B-4	R5310	A-3
C5307	B-4	R5311	A-3
C5308	B-3	R5312	B-4
C5309	A-3	R5313	B-4
C5310	B-4	R5314	B-3
C5311	A-4	R5315	B-3
C5312	A-3	R5316	A-3
C5313	B-3	R5317	B-3
		R5318	B-4
CN5301	B-4	R5319	A-4
CN5302	A-1	R5320	A-2
		R5321	A-3
D5301	A-3	R5322	A-3
D5302	A-4	R5323	A-4
		R5324	A-4
IC5301	A-4	R5325	B-4
L5301	A-4		
Q5301	B-3		
Q5302	A-2		
Q5303	A-2		
Q5304	A-4		
Q5305	B-4		
R5302	A-2		
R5302	A-4		
R5303	A-1		
R5303	A-3		

VF-120 BOARD (SIDE B)

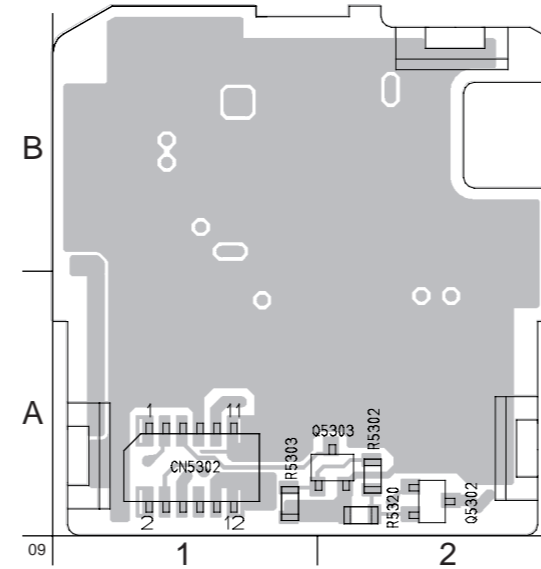

VF-120 BOARD (SIDE A)

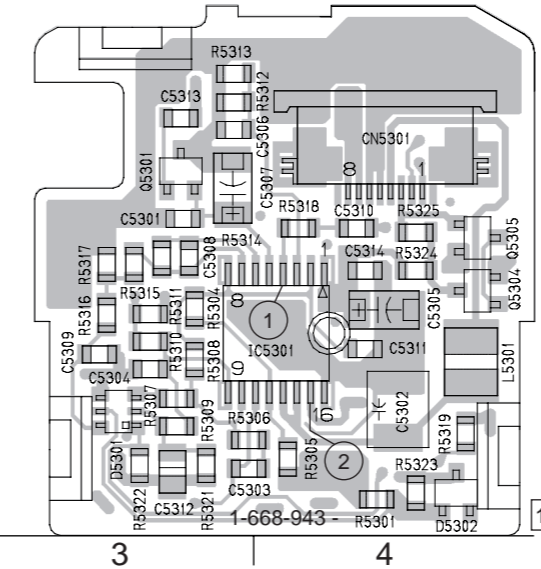

- For Printed Wiring Boards.
- This board is four-layer print board. However, the patterns of layers 2 to 3 have not been included in the diagram.

There are few cases that the part isn't mounted in this model is printed on this diagram.

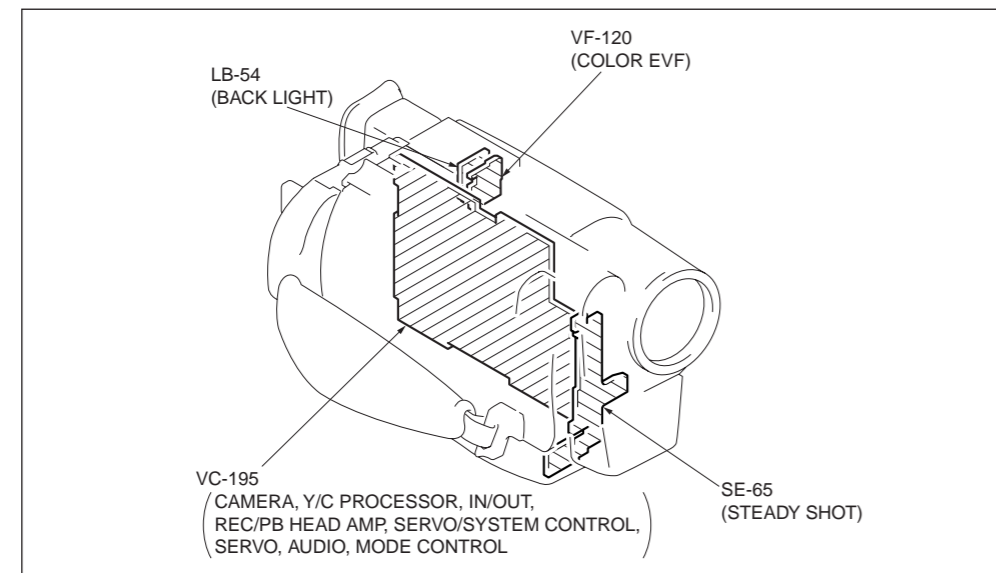
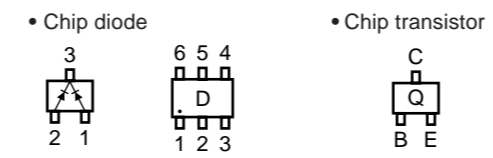

LB-54 BOARD

C5351	B-4
C5352	B-4
C5353	B-3
C5354	A-4
C5355	A-4
C5356	B-4
CN5351	B-3
D5351	B-2
L5351	B-3
L5352	B-4
ND5351	A-1
Q5351	A-4
R5351	B-3
T5351	A-3

LB-54 BOARD (SIDE B)

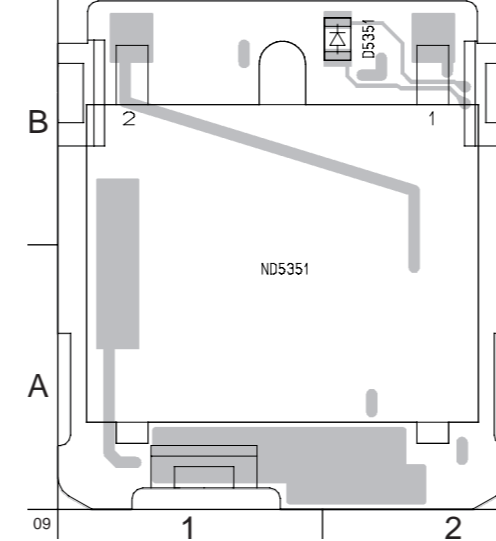

LB-54 BOARD (SIDE A)

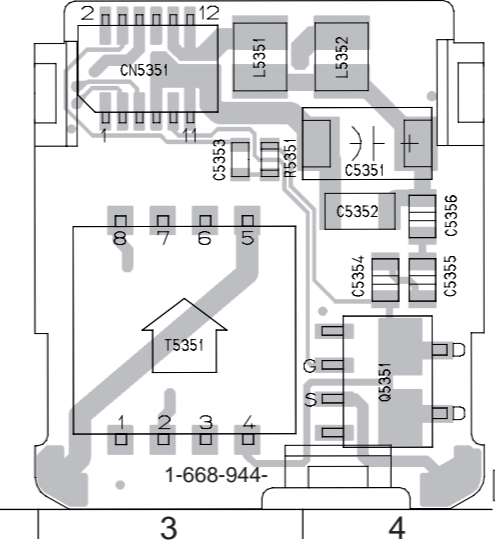

CCD-TR311/TR311E/TR411E/TR412E/TR511E/TR512E/
TR640E/TR730E/TR840E/TR845E

DD-105 (POWER) PRINTED WIRING BOARD
- Ref No. DD-105 BOARD: 2,000 series -

DD-105 BOARD

C801	E-3	L801	D-7	R823	D-7
C802	E-3	L802	D-7	R824	D-2
C803	D-3	L803	D-8	R825	D-4
C804	E-3	L804	E-9	R826	D-4
C805	E-3	L805	B-7	R827	E-3
C806	E-3	L806	C-8	R828	F-3
C807	E-2	L807	C-7	R829	D-2
C808	E-3	L808	B-8	R830	D-2
C809	D-2	L809	C-7	R831	F-4
C810	D-3	L810	B-4	R832	D-4
C811	D-2	L811	B-3	R833	D-2
C812	D-4	L812	B-3	R834	D-2
C813	D-2	L813	B-3	R835	D-4
C814	E-8	L814	A-3	R836	D-4
C815	C-4	L815	A-3	R837	D-2
C816	E-9	L816	B-3	R838	D-3
C817	E-8	L817	A-3	R839	C-2
C819	C-3	L819	A-2	R840	C-3
C820	C-3	L819	A-3	R841	C-3
C821	C-2	L820	D-8	R842	E-2
C822	E-8			R843	C-2
C823	C-4	LF801	D-7	R849	E-2
C824	C-2			R850	E-2
C825	C-2	PS801	F-3	R852	D-2
C826	D-8	PS802	F-2	R853	D-2
C827	F-2	PS803	F-3	R854	D-2
C828	E-2	PS804	F-2	R854	D-2
C829	F-2	PS805	F-2	R859	E-3
C830	D-2	PS806	F-3	R864	E-3
C831	E-2			R865	A-2
C832	B-3	Q801	F-4	R866	B-2
C833	B-3	Q802	E-4	R867	E-2
C834	C-4	Q803	E-3	R868	A-2
C836	B-2	Q804	F-3	R870	A-7
C837	C-2	Q805	F-3	R871	A-7
C838	C-3	Q806	C-2	R872	B-6
C840	D-8	Q807	C-3	R873	A-5
C841	B-4	Q808	C-3	R874	B-5
C843	C-4	Q809	B-3	R875	A-2
C844	A-3	Q810	C-2	R876	B-5
C846	B-3	Q812	C-3	R877	A-7
C847	B-7	Q813	C-2	R878	A-2
C848	B-7	Q814	C-2	R879	B-6
C849	A-2	Q815	C-2	R880	B-6
C850	A-3	Q817	C-3	R881	B-6
C851	B-4	Q819	B-6	R882	B-6
C852	B-8	Q820	E-3	R883	A-8
C853	B-7	Q823	A-2	R884	B-8
C854	B-3	Q824	E-2	R885	B-7
C855	A-3	Q826	A-7	R887	B-8
C856	E-3	Q827	A-2	R888	B-8
C857	A-2	Q828	B-6	R889	A-7
C860	A-6	Q829	B-6	R890	A-7
C861	A-7	Q830	B-6	R891	A-8
C862	A-2	Q831	A-7	R892	A-8
C863	B-6	Q832	B-6	R893	B-8
C864	A-5	Q833	A-2	R894	A-7
C866	B-6	Q834	B-6	R895	A-6
C867	A-7	Q835	A-8	R896	A-8
C868	B-6	Q836	A-8	R897	A-8
C869	A-6	Q837	A-7	R898	A-7
C871	B-2	Q838	A-8	R899	A-7
C872	F-4	Q839	B-8	R900	A-6
C873	A-2	Q840	A-8	R901	A-6
C874	A-7	Q841	A-7	R902	A-6
C875	B-2	Q842	A-7	R903	A-8
C876	C-6	Q843	A-7	R904	A-8
C877	D-6	Q844	A-8	R905	A-8
C885	A-6	Q845	A-8	R906	A-8
		Q846	A-7	R907	A-8
		Q847	A-6	R908	B-2
		Q848	A-8	R910	B-2
		Q849	A-7	R911	B-2
		Q850	A-8	R912	B-2
		Q851	E-4	R913	E-2
		Q852	B-2	R914	D-2
		Q853	B-2	R915	E-2
		Q854	B-2	R916	A-7
		Q855	B-2	R917	A-7
		Q856	A-6	R918	A-2
		Q857	C-3	R919	A-7
		Q858	C-3	R920	A-7
		Q859	C-3	R924	C-5
		Q860	C-3	R925	G-3
		Q861	C-3	R926	F-7
		Q862	C-3	R927	F-7
		Q863	C-3	R928	F-7
		Q864	C-3	R929	F-7
		Q865	C-3	R930	F-7
		Q866	C-3	R931	F-7
		Q867	C-3	R932	F-7
		Q868	C-3	R933	F-7
		Q869	C-3	R934	F-7
		Q870	C-3	R935	F-7
		Q871	C-3	R936	F-7
		Q872	C-3	R937	F-7
		Q873	C-3	R938	F-7
		Q874	C-3	R939	F-7
		Q875	C-3	R940	F-3
		Q876	C-3	R941	G-3
		Q877	C-3	R942	E-9
		Q878	C-3	R943	G-3
		Q879	C-3		
		Q880	C-3		
		Q881	C-3		
		Q882	C-3		
		Q883	C-3		
		Q884	C-3		
		Q885	C-3		
		Q886	C-3		
		Q887	C-3		
		Q888	C-3		
		Q889	C-3		
		Q890	C-3		
		Q891	C-3		
		Q892	C-3		
		Q893	C-3		
		Q894	C-3		
		Q895	C-3		
		Q896	C-3		
		Q897	C-3		
		Q898	C-3		
		Q899	C-3		
		Q900	C-3		
		Q901	C-3		
		Q902	C-3		
		Q903	C-3		
		Q904	C-3		
		Q905	C-3		
		Q906	C-3		
		Q907	C-3		
		Q908	C-3		
		Q909	C-3		
		Q910	C-3		
		Q911	C-3		
		Q912	C-3		
		Q913	C-3		
		Q914	C-3		
		Q915	C-3		
		Q916	C-3		
		Q917	C-3		
		Q918	C-3		
		Q919	C-3		
		Q920	C-3		
		Q921	C-3		
		Q922	C-3		
		Q923	C-3		
		Q924	C-3		
		Q925	C-3		
		Q926	C-3		
		Q927	C-3		
		Q928	C-3		
		Q929	C-3		
		Q930	C-3		
		Q931	C-3		
		Q932	C-3		
		Q933	C-3		
		Q934	C-3		
		Q935	C-3		
		Q936	C-3		
		Q937	C-3		
		Q938	C-3		
		Q939	C-3		
		Q940	C-3		
		Q941	C-3		
		Q942	C-3		
		Q943	C-3		
		Q944	C-3		
		Q945	C-3		
		Q946	C-3		
		Q947	C-3		
		Q948	C-3		
		Q949	C-3		
		Q950	C-3		
		Q951	C-3		
		Q952	C-3		
		Q953	C-3		
		Q954	C-3		
		Q955	C-3		
		Q956	C-3		
		Q957	C-3		
		Q958	C-3		
		Q959	C-3		
		Q960	C-3		
		Q961	C-3		
		Q962	C-3		
		Q963	C-3		
		Q964	C-3		
		Q965	C-3		
		Q966	C-3		
		Q967	C-3		
		Q968	C-3		
		Q969	C-3		
		Q970	C-3		
		Q971	C-3		
		Q972	C-3		
		Q973	C-3		
		Q974	C-3		
		Q975	C-3		
		Q976	C-3		
		Q977	C-3		
		Q978	C-3		
		Q979	C-3		
		Q980	C-3		
		Q981	C-3		
		Q982	C-3		
		Q983	C-3		
		Q984	C-3		
		Q985	C-3		
		Q986	C-3		
		Q987	C-3		
		Q988	C-3		
		Q989	C-3		
		Q990	C-3		
		Q991	C-3		
		Q992	C-3		
		Q993	C-3		
		Q994	C-3		
		Q995	C-3		
		Q996	C-3		
		Q997	C-3		
		Q998	C-3		
		Q999	C-3		
		Q1000	C-3		
		Q1001	C-3		
		Q1002	C-3		
		Q1003	C-3		
		Q1004	C-3		
		Q1005	C-3		
		Q1006	C-3		
		Q1007	C-3		
		Q1008	C-3		
		Q1009	C-3		
		Q1010	C-3		
		Q1011	C-3		
		Q1012	C-3		
		Q1013	C-3		
		Q1014	C-3		
		Q1015	C-3		
		Q1016	C-3		
		Q1017	C-3		
		Q1018	C-3		
		Q1019	C-3		
		Q1020	C-3		
		Q1021	C-3		
		Q1022	C-3		
		Q1023	C-3		
		Q1024	C-3		
		Q1025	C-3		
		Q1026	C-3		
		Q1027	C-3		
		Q1028	C-3		
		Q1029	C-3		
		Q1030	C-3		
		Q1031	C-3		
		Q1032	C-3		
		Q1033	C-3		
		Q1034	C-3		
		Q1035	C-3		
		Q1036	C-3		
		Q1037	C-3		
		Q1038	C-3		
		Q1039	C-3		
		Q1040	C-3		
		Q1041	C-3		
		Q1042	C-3		
		Q1043	C-3		
		Q1044	C-3		
		Q1045	C-3		
		Q1046	C-3		
		Q1047	C-3		
		Q1048	C-3		
		Q1049	C-3		
		Q1050	C-3		
		Q1051	C-3		
		Q1052	C-3		
		Q1053	C-3		
		Q1054	C-3		
		Q1055	C-3		
		Q1056	C-3		
		Q1057	C-3		
		Q1058	C-3		
		Q1059	C-3		
		Q1060	C-3		
		Q1061	C-3		
		Q1062	C-3		
		Q1063	C-3		
		Q1064	C-3		
		Q1065	C-3		
		Q1066	C-3		
		Q1067	C-3		
		Q1068	C-3		
		Q1069	C-3		
		Q1070	C-3		
		Q1071	C-3		

DD-105 BOARD

POWER
-REF. NO.: 2-000 SERIES-
XX MARK: NO MOUNT
NO MARK: CAMERA REC mode
() : CAMERA REC mode (COLOR EVF ON)
< > : CAMERA REC mode (B/W EVF ON)

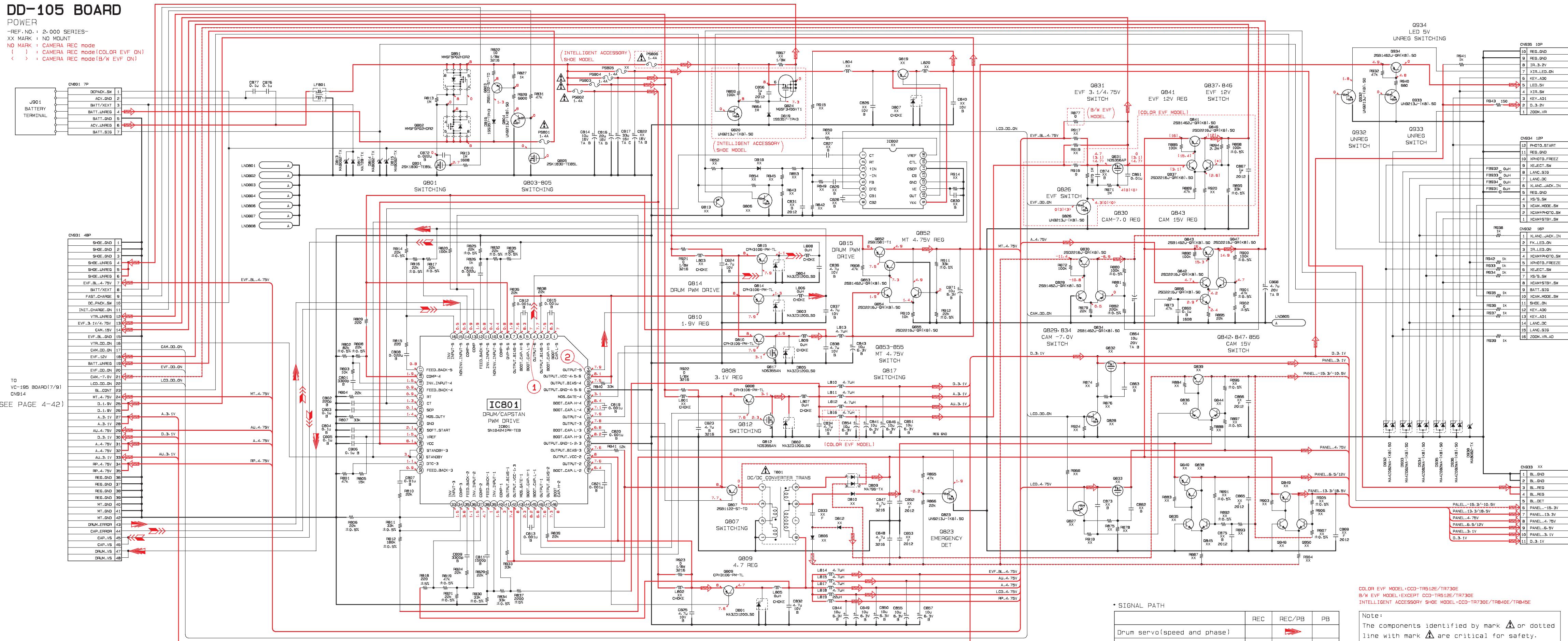

TO VC-195 BOARD(7/9)
CN914
(SEE PAGE 4-42)

TO CONTROL SWITCH BLOCK
FK-8500
(SEE PAGE 4-54)

TO CONTROL SWITCH BLOCK
SS-8500
(SEE PAGE 4-54)

TO VC-195 BOARD(9/9)
CN912
(SEE PAGE 4-50)

DD-105 BOARD CAMERA REC

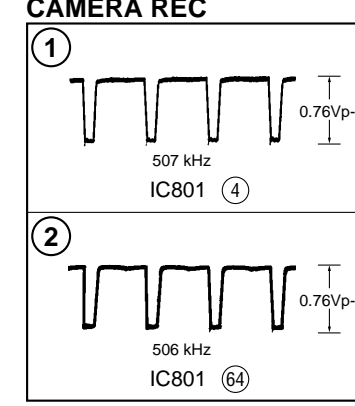

IC801 (4)
IC801 (64)

* SIGNAL PATH

	REC	REC/PB	PB
Drum servo(speed and phase)	→	→	→
Capstan servo(speed and phase)	→	→	→

Note:
The components identified by mark Δ or dotted line with mark Δ are critical for safety.
Replace only with part number specified.